

**2026**

Rules for the Classification of Steel Ships

**Part 10 Hull Structure and Equipment of Small Steel Ships**

---

---

Rules

**2026**

Guidance Relating to the Rules for the Classification of Steel ships

**Part 10 Hull Structure and Equipment of Small Steel Ships**

---

---

Guidance



**2026**

**Rules for the Classification of Steel Ships**

---

**Part 10**

**Hull Structure and Equipment of  
Small Steel Ships**

---

**APPLICATION OF PART 10**  
**"HULL STRUCTURE AND EQUIPMENT OF SMALL STEEL SHIPS"**

1. Unless expressly specified otherwise, the requirements in these Rules apply to ships for which contracts for construction are signed on or after 1 July 2026
2. The amendments to the Rules for 2025 edition and their effective date are as follows;

**Effective Date : 1 July 2026 (ships for which the application is submitted)**

---

**CHAPTER 7 DOUBLE BOTTOMS**

**Section 1 General**

- 104. has been amended.

**CHAPTER 15 DEEP TANKS**

**Section 3 Fittings of Deep Tanks**

- 304. has been amended.

# CONTENTS

<b>CHAPTER 1 GENERAL .....</b>	<b>1</b>
Section 1 Definitions .....	1
Section 2 General .....	3
Section 3 Materials, Welding and Construction .....	4
<b>CHAPTER 2 STEMS AND STERN FRAMES .....</b>	<b>11</b>
Section 1 Stems .....	11
Section 2 Stern Frames .....	11
<b>CHAPTER 3 LONGITUDINAL STRENGTH .....</b>	<b>15</b>
Section 1 General .....	15
Section 2 Bending Strength .....	15
Section 3 Buckling Strength .....	17
<b>CHAPTER 4 PLATE KEELS AND SHELL PLATINGS .....</b>	<b>19</b>
Section 1 General .....	19
Section 2 Plate Keels .....	19
Section 3 Shell Plating for Midship Part of Ship .....	19
Section 4 Shell Plating for End Parts .....	20
Section 5 Side Plating in way of Superstructure .....	21
Section 6 Local Compensation of Shell Plating .....	21
<b>CHAPTER 5 DECKS .....</b>	<b>23</b>
Section 1 General .....	23
Section 2 Effective Sectional Area of Strength Deck .....	23
Section 3 Deck Plating .....	24
<b>CHAPTER 6 SINGLE BOTTOMS .....</b>	<b>25</b>
Section 1 General .....	25
Section 2 Centre Keelsons .....	25
Section 3 Side Keelsons .....	25
Section 4 Floor Plates .....	26
Section 5 Longitudinals .....	28
Section 6 Strengthened Bottom Forward .....	28
<b>CHAPTER 7 DOUBLE BOTTOMS .....</b>	<b>29</b>
Section 1 General .....	29
Section 2 Centre Girders .....	31
Section 3 Side Girders .....	32

Section 4	Solid Floors .....	32
Section 5	Bottom Longitudinals .....	33
Section 6	Inner Bottom Plating and Margin Plates .....	34
Section 7	Hold Frame Brackets .....	35
Section 8	Open Floors .....	35
Section 9	Construction of Strengthened Bottom Forward .....	36
<b>CHAPTER 8</b>	<b>FRAMES .....</b>	<b>39</b>
Section 1	General .....	39
Section 2	Frame Spacing .....	39
Section 3	Transverse Hold Frames .....	40
Section 4	Side Longitudinals .....	40
Section 5	Tween Deck Frames .....	42
Section 6	Frames in Both Peaks .....	43
<b>CHAPTER 9</b>	<b>CANTILEVER BEAM CONSTRUCTION .....</b>	<b>45</b>
Section 1	Cantilever Beams .....	45
Section 2	Web Frames .....	46
Section 3	Connection of Cantilever Beams to Web Frames .....	48
<b>CHAPTER 10</b>	<b>BEAMS .....</b>	<b>49</b>
Section 1	General .....	49
Section 2	Deck Load .....	49
Section 3	Longitudinal Beams .....	51
Section 4	Transverse Beams .....	52
Section 5	Beams on Bulkhead Recesses and Others .....	52
Section 6	Beams on the Top of Deep Tanks .....	52
Section 7	Deck Beams Supporting Specially Heavy Loads .....	52
Section 8	Beams on Deck Carrying Unusual Cargoes .....	52
<b>CHAPTER 11</b>	<b>DECK GIRDERS .....</b>	<b>53</b>
Section 1	General .....	53
Section 2	Longitudinal Deck Girders .....	53
Section 3	Transverse Deck Girders .....	55
Section 4	Deck Girders in Tanks .....	56
Section 5	Hatch Side Girders .....	56
Section 6	Hatch End Girders .....	57
<b>CHAPTER 12</b>	<b>PILLARS .....</b>	<b>59</b>
Section 1	General .....	59
Section 2	Scantling of Pillars .....	59

<b>CHAPTER 13</b>	<b>ARRANGEMENTS TO RESIST PANTING</b> .....	<b>63</b>
Section 1	General .....	63
Section 2	Arrangements to resist Panting Forward the Collision Bulkhead .....	63
Section 3	Arrangements to resist Panting Aft Peak Bulkhead .....	66
<b>CHAPTER 14</b>	<b>WATERTIGHT BULKHEADS</b> .....	<b>67</b>
Section 1	Arrangement .....	67
Section 2	Construction .....	68
Section 3	Watertight Doors .....	72
<b>CHAPTER 15</b>	<b>DEEP TANKS</b> .....	<b>73</b>
Section 1	General .....	73
Section 2	Bulkheads of Deep Tanks .....	73
Section 3	Fittings of Deep Tanks .....	76
Section 4	Welding of Corrugated Bulkheads .....	76
<b>CHAPTER 16</b>	<b>SUPERSTRUCTURES AND DECKHOUSES</b> .....	<b>77</b>
Section 1	General .....	77
Section 2	Construction .....	77
Section 3	Access Openings in Superstructure End Bulkheads .....	79
<b>CHAPTER 17</b>	<b>MACHINERY SPACES AND ENGINE CASINGS</b> .....	<b>81</b>
Section 1	General .....	81
Section 2	Main Engine Foundations .....	81
Section 3	Construction of Boiler Rooms .....	81
Section 4	Thrust Blocks and Foundations .....	82
Section 5	Machinery Space Openings .....	82
<b>CHAPTER 18</b>	<b>TUNNELS AND TUNNEL RECESSES</b> .....	<b>85</b>
Section 1	General .....	85
<b>CHAPTER 19</b>	<b>HATCHWAYS AND OTHER DECK OPENINGS</b> .....	<b>87</b>
Section 1	General .....	87
<b>CHAPTER 20</b>	<b>BOW DOORS, SIDE AND STERN DOORS</b> .....	<b>89</b>
Section 1	Bow doors and Inner Doors .....	89
Section 2	Side and Stern Door .....	89
<b>CHAPTER 21</b>	<b>BULWARKS FREEING PORTS, SIDE SCUTTLES, VENTILATORS AND PERMANENT GANGWAYS</b> .....	<b>91</b>
Section 1	Bulwarks .....	91
Section 2	Freeing Ports .....	91
Section 3	Side Scuttles .....	91

Section 4 Ventilators .....	91
Section 5 Permanent Gangways .....	91
<b>CHAPTER 22 EQUIPMENT NUMBER AND EQUIPMENT .....</b>	<b>93</b>
Section 1 General .....	93
Section 2 Equipment Number .....	93
Section 3 Shipboard Fittings and Supporting Hull Structures associated with Towing and Mooring .....	93
<b>CHAPTER 23 OIL TANKERS .....</b>	<b>95</b>
Section 1 General .....	95
Section 2 Hatchways, Gangways and Freeing Arrangements .....	97
Section 3 Longitudinal Frames and Beams in Cargo Oil Spaces .....	98
Section 4 Girders and Transverses in Cargo Oil Spaces .....	99
Section 5 Trunks .....	101
Section 6 Bulkheads in Cargo Oil Space .....	102
<b>CHAPTER 24 DOUBLE HULL TANKERS .....</b>	<b>103</b>
Section 1 General .....	103
Section 2 Bulkhead Plating .....	104
Section 3 Frames, Stiffeners and Longitudinal Beams .....	106
Section 4 Structural Members in Double Bottoms .....	108
Section 5 Structural Members in Double Side Hull .....	108
Section 6 Girders and Transverses in Cargo Oil Tanks and Deep Tanks .....	108
Section 7 Strengthened Bottom Forward .....	110
Section 8 Structural Details .....	110
Section 9 Special Requirements for Corrosion .....	110
Section 10 Special Requirements for Hatchways and Permanent Gangways .....	111

## CHAPTER 1 GENERAL

### Section 1 Definitions

#### 101. Application **【See Guidance】**

The definitions of term which appear in this Rule are to be as specified in this Section, unless otherwise specified elsewhere, and the definitions of terms not specified in this Rule are to be as specified **Pt 3** and **Pt 4**.

#### 102. Rule Length (2020) **【See Guidance】**

The rule length ( $L$ ) is the distance in *metres* measured on the waterline at the scantling draught from the fore side of stem to the after side of rudder post in case of a ship with rudder post, or to the axis of rudder stock in case of a ship without rudder post or stern post.  $L$  is not to be less than 96 % and need not be greater than 97 % of the extreme length on the waterline at the scantling draught. In ships without rudder stock (e.g. ships fitted with azimuth thrusters),  $L$  is to be taken equal to 97% of the extreme length on the waterline at the scantling draught. In ships with unusual stern and bow arrangement the rule length,  $L$  will be specially considered.

#### 103. Length for freeboard

The length of ship for freeboard ( $L_f$ ) is 96 % of the length in *metres* measured from the fore side of stem to the aft side of aft end shell plate on the waterline at 85 % of the least moulded depth measured from the top of keel, or the length in *metres* measured from the fore side of stem to the axis of rudder stock on that waterlines, whichever is the greater. However, where the stem contour is concave above the waterline at 85 % of the least moulded depth, the forward terminal of this length is to be taken at the vertical projection to this waterline of the aftermost point of the stem contour. For ships without a rudder stock, the length of ship for freeboard is 96 % of the length measured from the fore side of stem to the aft side of aft end shell plate on the waterline at 85 % of the least moulded depth measured from the top of keel. The waterline on which this length is measured is taken to be parallel to the load line defined in **108**.

#### 104. Breadth (2020) **【See Guidance】**

The breadth of ship ( $B$ ) is the horizontal distance in *metres* from the outside of frame to the outside of frame measured amidships at the scantling draught,  $d_s$ .

#### 105. Depth **【See Guidance】**

The depth of ship ( $D$ ) is the vertical distance in *metres* at the middle of  $L$  measured from the top of keel to the top of the freeboard deck beam at side. Where watertight bulkheads extend to a deck above the freeboard deck and are to be registered as effective to that deck,  $D$  is the vertical distance to that bulkhead deck.

#### 106. Midship

The midship part of ship is the part for  $0.4 L$  amidships unless otherwise specified.

#### 107. Fore and aft end

The fore and aft end part means the part covering  $0.1 L$  from the fore and aft end of the ship.

#### 108. Load line

The load line is the waterline corresponding to the designed summer load draught in case of a ship which is required to be marked with load lines and the waterline corresponding to the designed maximum draught in case of a ship which is not required to be marked with load lines.

### 109. Load draught

The load draught ( $d$ ) is the vertical distance in *metres* from the top of keel to the load line measured at the middle of  $L_f$  in case of a ship which is required to be marked with load lines and at the middle of  $L$  in case of a ship which is not required to be marked with load lines.

### 110. Full load displacement

The full load displacement ( $D$ ) is the displacement (including shell platings and appendages, etc.) in tons corresponding to the summer load line.

### 111. Block coefficient (2020)

The block coefficient ( $C_b$ ) is the moulded coefficient corresponding to waterline at the scantling draught,  $d_s$ , based on rule length,  $L$  and moulded breadth,  $B$ .

$$C_b = \frac{\text{Moulded displacement [m}^3\text{] at scantling draught } d_s}{L \times B \times d_s}.$$

### 112. Strength deck

The strength deck at a part of ship's length is the uppermost deck at that part to which the shell plates extend. However, in way of superstructures, except sunken superstructures, not exceeding  $0.15 L$  in length, the strength deck is the deck just below the superstructure deck. The deck just below the superstructure deck may be taken as the strength deck even in way of the superstructure exceeding  $0.15 L$  in length at the option of the designer.

### 113. Freeboard deck

1. The freeboard deck is normally the uppermost continuous deck. However, in cases where openings without permanent closing means exist on the exposed part of the uppermost continuous deck or where openings without permanent watertight closing means exist on the side of the ship below that deck, the freeboard deck is the continuous deck below that deck.
2. For ships having a discontinuous freeboard deck (e.g. a stepped freeboard deck), the freeboard deck is to be determined as follows.
  - (1) Where a recess in the freeboard deck extends to both sides of the ship and is in excess of 1 m in length, the lowest line of the exposed deck and the continuation of that line parallel to the upper part of the deck is taken as the freeboard deck.
  - (2) Where a recess in the freeboard deck does not extend to the sides of the ship or is not in excess of 1 m in length, the upper part of the deck is taken as the freeboard deck.
  - (3) Recesses not extending from side to side in a deck below the exposed deck, designated as the freeboard deck, may be disregarded, provided all openings in the weather deck are fitted with weathertight closing appliances.
3. Where a ship has multiple decks, an actual deck lower than one that complies with the freeboard deck defined above in **1** or **2** can be deemed the freeboard deck. However, this lower deck is to be continuous in a fore and aft direction at least between the machinery space and peak bulkheads and continuous athwartships.
  - (1) When this lower deck is stepped, the lowest line of the deck and the continuation of that line parallel to the upper part of the deck is taken as the freeboard deck.
  - (2) When a lower deck is designated as the freeboard deck, such deck as a minimum shall consist of suitably framed stringers at the ship sides and transversely at each watertight bulkhead which extends to the upper deck, within cargo spaces.

### 114. Fore end and Aft end

The fore end is the start point of forward side, where measuring the length of ship  $L$  in **102.**, and aft end is the end point of afterward side of  $L$ .

### 115. Scantling draught (2020)

Scantling draught,  $d_s$ , at which the strength requirements for the scantlings of the ship are met and represents the full load condition. The scantling draught is to be not less than that corresponding to the assigned freeboard.

## Section 2 General

### 201. Application

1. The requirements in this Part, unless otherwise specified elsewhere, are framed for ships of normal form and proportions of less than 90 m in length to be classed for unrestricted service. The requirements not specified in this Part are generally to comply with those in **Pt 3** and **Pt 4**.
2. Hull construction, equipment and scantlings of ships to be classed for restricted service may be appropriately modified according to the condition of service. **【See Guidance】**
3. In the application of relevant provisions in this Rule to ships which are not required to be marked with load line,  $L_f$  is to be read as  $L$  and  $B_f$  as  $B$ .

### 202. Exception in application **【See Guidance】**

In ships of which length is less than 24 m or in ships to which requirements in this Rule for some special reason are not directly applicable, hull construction, equipment, arrangement and scantlings are to be at the discretion of the Society, notwithstanding the provisions in **201**.

### 203. Ships of unusual form or proportion, or intended for carriage of special cargoes **【See Guidance】**

In ships of unusual form or proportion, or intended for carriage of special cargoes, the requirements concerning hull construction, equipment, arrangement and scantlings will be decided individually basing upon the general principle of this Rule, notwithstanding the requirements in this Rule.

### 204. Equivalency

The equivalence of alternative and novel features which deviate from or are not directly applicable to the Rules is to be in accordance with **Pt 1, Ch 1 105**. of Rules for the Classification of Steel Ships. (2021)

### 205. Passenger ships

Hull construction, equipment, arrangement and scantlings of passenger ships are to be specially considered with respect to the design features in addition to the requirements in **201**. to **203**.

### 206. Stability of ship

The requirements in this Rule are framed for ships having appropriate stability in all conceivable conditions. The Society emphasizes that the special attention be paid to the stability by the builders in design and construction stage and by the masters while in service.

### 207. Carriage of oil or other flammable liquid substances

1. The requirements for construction and arrangement for carriage of fuel oils specified in this Rule are to be applied to the case intended to carry fuel oils having a flashpoint of 60°C or above at a closed cup test.
2. The construction and arrangement for carriage of fuel oils having a flashpoint 60°C or below at a closed cup test, are to be in accordance with the requirements provided in Part, and to comply with the requirements in **Pt 8, Ch 2, 401**. in addition.
3. The construction and arrangement of deep oil tanks intended to carry cargo oils are to be correspondingly in accordance with the requirements in **Ch 23** and **Ch 24**.

### 208. Equipment **【See Guidance】**

Masts, riggings, cargo handling appliances, anchoring and mooring arrangements, and other than those specified in this Rule are to be suitably arranged according to their uses and are to satisfy the tests as may be required by the Surveyor.

### 209. Fittings for examination

Ladders, steps or other facilities, by which internal examination can be performed safely, are to be provided in fore and after peak tanks, deep tanks, cofferdams and enclosed compartments which are similar to the above-mentioned tanks, except those exclusively used for fuel oil or lubricating oil.

## Section 3 Materials, Welding and Construction

### 301. Materials **【See Guidance】**

1. The materials used for hull construction and equipment are to be those complying with the requirements in **Pt 2, Ch 1**, unless otherwise specified.
2. Where high tensile steels are used, the construction and scantlings are to be in accordance with the discretion of the Society, unless otherwise specified.
3. Where materials other than those specified in this rule are used, the use of such materials and corresponding scantlings are to be specially approved by the Society.
4. Materials used for the hull construction of ships classed for smooth water service are to be in accordance with the discretion of the Society. **【See Guidance】**
5. Application of steels
  - (1) The steels used for hull structures are to be of the grades provided in **Pt 2, Ch 1** in accordance with the requirements given in **Table 10.1.1** and **Table 10.1.3**. In applying these requirements, *B*, *D* or *E* may be substituted for *A*; *D* or *E* for *B*; *E* for *D*; *DH32* or *EH32* for *AH32*; *EH32* for *DH32*; *DH36* or *EH36* for *AH36*; and *EH36* for *DH36*; *DH40* or *EH40* for *AH40*; and *EH40* for *DH40*, respectively.
  - (2) For strength members not mentioned in **Table 10.1.1**, grades *A*, *AH32*, *AH36* and *AH40* may generally be used. The steel grade is to correspond to the as-built plate thickness and material class.
  - (3) The grades of steel to be used in the hull construction are to be clearly indicated on the hull structural plans.

Table 10.1.1 Material classes

Structural member category	Material classes
○ SECONDARY : A1 Longitudinal bulkhead strakes, other than those belonging to the Primary category A2 Deck plating exposed to weather, other than that belonging to the Primary or Special category A3 Side plating	- Within 0.4 $L$ amidships : I - Outside 0.4 $L$ amidships : A/AH
○ PRIMARY : B1 Bottom plating including keel plate B2 Strength deck plating, excluding that belonging to the Special category B3 Continuous longitudinal plating of strength members above strength deck, excluding hatch coamings B4 Uppermost strake in longitudinal bulkhead B5 Vertical strake (hatch side girder) and uppermost sloped strake in top wing tank B6 Longitudinal hatch coamings of length greater than 0.15 $L$	- Within 0.4 $L$ amidships : II - Outside 0.4 $L$ amidships : A/AH
○ SPECIAL : C1 Sheer strake at strength deck <sup>(1)</sup> C2 Stringer plate in strength deck <sup>(1)</sup> C3 Deck strake at longitudinal bulkhead, excluding deck plating in way of inner-skin bulkhead of double-hull ships <sup>(1)</sup>	- Within 0.4 $L$ amidships : III - Outside 0.4 $L$ amidships : II - Outside 0.6 $L$ amidships : I
C4 Strength deck plating at outboard corners of cargo hatch openings (bulk carriers, ore carriers, combination carriers and other ships with similar hatch opening configurations)	- Within 0.6 $L$ amidships : III - Outside 0.6 $L$ amidships : II
C5 Bilge strake in ships with double bottom over the full breadth and length less than 150 m <sup>(1)</sup>	- Within 0.6 $L$ amidships : II - Outside 0.6 $L$ amidships : I
C6 Bilge strake in other ships <sup>(1)</sup>	- Within 0.4 $L$ amidships : III - Outside 0.4 $L$ amidships : II - Outside 0.6 $L$ amidships : I
(NOTES) (1) Single strakes required to be class III within 0.4 $L$ amidships are to have breadths not less than $5L + 800$ (mm), need not be greater than 1800 mm, unless limited by the geometry of the ship's design. (2) The symbols in the table mean the grades of steel as follows : AH : AH 32, AH 36 and AH 40 DH : DH 32, DH 36 and DH 40 EH : EH 32, EH 36 and EH 40	

Table 10.1.2 Minimum Material Grades for ships with ice strengthening

Structural member category	Material grade
Shell strakes in way of ice strengthening area for plates	B/AH



### 305. Brackets

- Secondary members, such as longitudinals, beams, frames and stiffeners forming part of the hull structure, are generally to be connected at their ends with  $t_b$  not to be less than that obtained from the following formula. Where it is desired to adopt bracketless connections, the proposed arrangements will be individually considered.

$$t_b = C_1 \sqrt{Z} + 4.5 \text{ (mm)}$$

where :

$Z$  = section modulus ( $\text{cm}^3$ ) specified in the following (a) through (c) :

- Bracket connecting stiffener to primary member, section modulus of the stiffener
- Bracket at the head of a main transverse frame where frame terminates, section modulus of the frame
- Elsewhere the lesser section modulus of the members being connected by the bracket

$C_1$  = coefficient given in followings

$C_1 = 0.27$ , where a flange is not fitted

$C_1 = 0.23$ , where a flange is fitted

- Where a flange is fitted, its breadth  $w_f$  is not to be less than that obtained from following formula. Where the length of larger arm exceeds 800 mm, the free edges of brackets are to be stiffened by flange or other means, except where tripping brackets or the like are provided.

$$w_f = \frac{Z}{33} + 45 \text{ (mm)}$$

where :

$Z$  = as specified in **Par 1**

- The lengths of bracket arms measured from shown in **Fig 10.1.1** are not to be less than those obtained from the following formulae. The lengths of bracket arms of tank side and hopper side are to be increased by 20 % greater than those required.

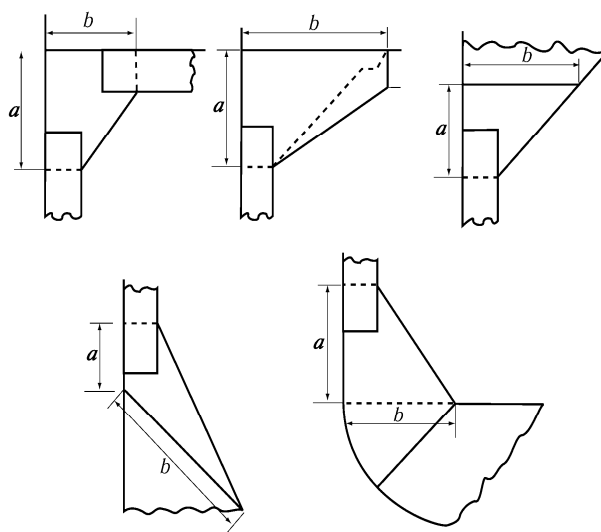

Fig 10.1.1 Measurement of  $a$  and  $b$  for arms

$$a + b \geq 2.0 l \quad a \text{ and } b \geq 0.8 l$$

where :

$l$  = as given by the following formula, but in no case is to be taken as less than twice the web depth of the stiffener on which the bracket scantlings are to be based.

$$l = 180 \sqrt{\frac{Z}{14 + \sqrt{Z}}} - 90 \text{ (mm)}$$

where :  $Z$  = as specified in **Par 1**

### 306. Modification of $l$

Where brackets of not less thickness than that of the girder plates, the value of  $l$  specified in **Ch 9, Ch 11, Ch 12, Ch 14** and **Ch 15** may be modified in accordance with the following:

- (1) Where the face area of the bracket is not less than one-half of that of the girder and the face plates or flange on the girder is carried to the bulkhead, deck, tank top, etc., the length  $l$  may be measured to a point 0.15 m inside the toe of bracket. (See **Fig 10.1.2 (a)**)
- (2) Where the face sectional area of the bracket is less than one-half of that of the girder and the face plate or flange on the girder is carried to the bulkhead, deck, tank top, etc.,  $l$  may be measured to a point where the sum of sectional area of the bracket outside the line of girder and its free flanges is equal to the sectional area of free flanges of girder, or to a point 0.15 m inside the toe of bracket, whichever is the greater. (See **Fig 10.1.2 (b)**)

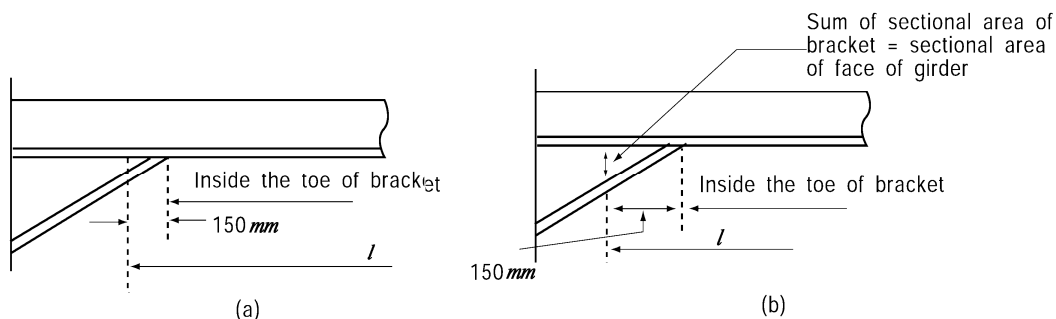

**Fig 10.1.2 Modification of  $l$**

- (3) Where brackets are provided and the face plate or flange on the girder are extended along the brackets to the bulkhead, deck, tank top, etc., the face plate or flange of bracket may be curved, but  $l$  is to be measured to the toe of bracket.
- (4) Brackets are not to be considered effective beyond the point where the arm on the girder is 1.5 times the length of arm on the bulkhead, deck, tank top, etc.
- (5) In no case is the allowance in  $l$  at either end to exceed one-quarter of the overall length of the girder.

### 307. Corrosion protection coating

1. All sea water ballast spaces having boundaries formed by the hull envelop are to have an effective corrosion protection coating in accordance with the manufacturer's requirements.
2. Corrosion protection coating for dedicated sea water ballast tanks in all types of Ships, double-side skin space of bulk carriers and cargo oil tanks of crude oil tankers are to be in accordance with the requirements in the **Guidance Pt 3, Ch 1, 801**.

### 308. Plating

Where plates with different thicknesses are joined, the change in the as-built plate thickness is not to exceed 50% of larger plate thickness in the load carrying direction. This also applies to the strengthening by local inserts, e.g. insert plates in double bottom girders, floors and inner bottom. ↓

## CHAPTER 2 STEMS AND STERN FRAMES

### Section 1 Stems

#### 101. Plate stems **【See Guidance】**

1. The thickness of steel plate stems at the load waterline is not to be less than that obtained from the following formula. However, above and below the load waterline, the thickness may be gradually tapered toward the stem head and the keel. And at the upper end of stem, it may be equal to the thickness of the side shell plating (at the fore end part) of the ship, and at the lower end of stem, it may be equal to the thickness of plate keel.

$$t = 0.1L + 3.0 \text{ (mm)}$$

2. Horizontal ribs are to be provided on the stem plates at an interval preferably not exceeding 1 m, and where the radius of curvature at the fore end of stem is large, proper reinforcement is to be made by providing with a centre line stiffener or by other means.

### Section 2 Stern Frames

#### 201. Application

The requirements in this Section apply only to stern frames without rudder post.

#### 202. Propeller posts **【See Guidance】**

1. Propeller posts of cast steel stern frames and those of plate stern frames are to be of shape suitable for the stream line at the after part of hull, and the scantlings are to be equivalent to the standards given by the formulae and figures in **Table 10.2.1**. Below the propeller boss, the breadth and thickness of propeller post are to be gradually increased in order to provide with strength and stiffness in proportion to those of the shoe pieces.
2. The thickness of boss of propeller post is not to be less than that obtained from the following formula:

$$t = 0.23d_p + 30 \text{ (mm)}$$

where :

$d_p$  = diameter (mm) of propeller shaft specified in **Pt 5, Ch 3, 204**.

3. The propeller posts of cast steel stern frames and those of plate stern frames are to be provided with ribs at a suitable interval. Where the radius of curvature is large, a centre line stiffener is to be provided.
4. In ships with relatively high speed for their length and in ships exclusively engaging in towing purposes, the scantlings of various parts of propeller posts are to be suitably increased.

Table 10.2.1 Standards of propeller posts

Cast steel	Steel plate
$W = 30\sqrt{L}$ $l = 40\sqrt{L}$ (mm) $T = \frac{3\sqrt{L}}{\sqrt{K^{(1)}}}$ (mm) $T_1 = \frac{3.7\sqrt{L}}{\sqrt{K^{(1)}}}$ (mm) $t_R = 0.6 T$ (mm) $R_{\min} = 40$ (mm)	$W = 37\sqrt{L}$ $l = 53\sqrt{L}$ (mm) $T = \frac{2.4\sqrt{L}}{\sqrt{K^{(2)}}}$ (mm) $t_R = 0.55 T$ (mm) $R_{\min} = 40$ (mm)
(NOTES) (1) Material factor $K$ for the Propeller post of cast steel is to be as Pt 4, Ch 1, Table 4.1.1. (2) Material factor $K$ for the Propeller post of steel plate is to be as Pt 4, Ch 1, Table 4.1.2.	

203. Shoe pieces **[See Guidance]**

- The scantlings of each cross-section of the shoe piece is to be determined by the following formulae (1) to (4), considering the bending moment and shear force acting on the shoe piece when the rudder force specified in **Pt 4, Ch 1, 201**, is applied to the rudder.

(1) The section modulus  $Z_z$  around the vertical Z-axis is not to be less than obtained from the following formula:

$$Z_z = \frac{MK_{sp}}{80} \text{ (cm}^3\text{)}$$

where:

$M$  = bending moment at the section considered, which is obtained from the following formula (N · m)

$$M = Bx \text{ (N} \cdot \text{m)}$$

$$M_{\max} = Bl \text{ (N} \cdot \text{m)}$$

where :

$B$  = supporting force in the pintle bearing (N), as given in **Pt 4, Ch 1, 102**.

$x$  = distance from the mid-point of the pintle bearing to the section considered (m)  
 (See **Fig. 10.2.1**)

$l$  = distance from the mid-point of the pintle bearing to the fixed point of the shoe piece (m) (See **Fig 10.2.1**)

$K_{sp}$  = material factor for the shoe piece as given in **Pt 4, Ch 1, 103**.

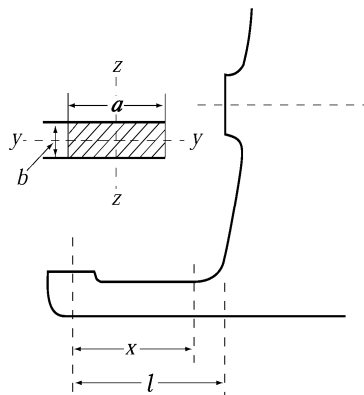

Fig 10.2.1 Shoe piece

- (2) The section modulus  $Z_y$  around the transverse Y-axis is not to be less than obtained from the following formula:

$$Z_y = 0.5 Z_z \text{ (cm}^3\text{)}$$

where :

$Z_z$  = as specified in (1)

- (3) The total sectional area  $A_s$  of the members in the Y-direction is not to be less than obtained from the following formula:

$$A_s = \frac{BK_{sp}}{48} \text{ (mm}^2\text{)}$$

where :

$B$  and  $K_{sp}$  = as specified in (1)

- (4) At no section within length  $l$  the equivalent stress  $\sigma_e$  is to exceed  $115 / K_{sp}$  (N/mm<sup>2</sup>). The equivalent stress  $\sigma_e$  is to be obtained from the following formula:

$$\sigma_e = \sqrt{\sigma_b^2 + 3\tau^2} \text{ (N/mm}^2\text{)}$$

where :

$\sigma_b$  = the bending stress acting on the shoe piece, are to be obtained from the following formula (N/mm<sup>2</sup>).

$$\sigma_b = \frac{M}{Z_z(x)} \text{ (N/mm}^2\text{)}$$

$\tau$  = the shear stress acting on the shoe piece, are to be obtained from the following formula (N/mm<sup>2</sup>).

$$\tau = \frac{B}{A_s(x)} \text{ (N/mm}^2\text{)}$$

where :

$Z_z(x)$  = the actual section modulus around the Z-direction at the section considered (cm<sup>3</sup>)

$A_s(x)$  = the actual sectional area around the Y-direction at the section considered (mm<sup>2</sup>)

$M$  and  $B$  = as specified in (1)

2. The thickness of steel plates forming the main part of shoe piece of steel plate stern frame is not to be less than that of steel plates forming the main part of propeller post. Ribs are to be arranged in the shoe piece below the propeller post, under brackets and at other suitable positions.

#### 204. Heel pieces **【See Guidance】**

Heel piece of stern frame is to be of length at least three times the frame space at that part and is to be strongly connected to the keel.

#### 205. Attachment of stern frame to floor plates

Stern frame is to be sufficiently extended upward immediately in front of the rudder stock, and is to be strongly connected to the transom floor of thickness not less than that obtained from the following formula. The transom floor is to be reinforced at the top of extended portion of the stern frame in order to avoid abrupt change of rigidity.

$$t = 0.035L + 9.0 \quad (\text{mm})$$

#### 206. Gudgeons (2019)

1. The depth of gudgeon is not to be less than the length of the pintle bearing.
2. The thickness of the gudgeon is not to be less than  $0.25 d_{p0}$ . For ships specified in **Pt 4, Ch 1, 104.**, the thickness of the gudgeon is to be appropriately increased.

where:

$d_{p0}$  = Actual diameter of the pintle measured at the outer surface of the sleeve(mm). ↓

## CHAPTER 3 LONGITUDINAL STRENGTH

### Section 1 General

#### 101. Special case in application **【See Guidance】**

In case there are items for which direct application of the requirements in this Chapter is deemed unreasonable, these items are to be in accordance with the discretion of the Society.

#### 102. Continuity of strength

Longitudinal members are to be so arranged as to maintain the continuity of strength.

#### 103. Loading manual **【See Guidance】**

As specified in Pt 3, Ch 3, 103.

#### 104. Longitudinal strength loading instrument **【See Guidance】**

As specified in Pt 3, Ch 3, 103.

### Section 2 Bending Strength

#### 201. Bending strength at amidships

1. The section modulus of the transverse sections of the hull, at the midship part is not to be less than the value of  $Z_1$  obtained from the formula given in **Table 10.3.1**. However, application of the requirement may be dispensed with to ships not exceeding 65 m in length at the discretion of the Society.
2. Notwithstanding the requirements of the preceding paragraph, the section modulus of the transverse section of hull at the midship part is not to be less than the value of  $Z_{\min}$  obtained from the formula given in **Table 10.3.1**.
3. Moment of inertia of the transverse section of hull at the middle point of  $L$  is not to be less than the value of  $I_{\min}$  obtained from the formula given in **Table 10.3.1** and the calculation method for moment of inertia of the actual transverse section is to be correspondingly in accordance with the requirements in **203**.
4. Scantlings of all continuous longitudinal members of hull girder based on the section modulus requirement in **Par 2** and **Par 3** are to be maintained within  $0.4 L$  amidships. However, in special cases, based on consideration of type of ship, hull form and loading conditions, the scantlings may be gradually reduced towards the ends of the  $0.4 L$  part.

#### 202. Bending strength at sections other than amidships

The bending strength of hull at sections other than  $0.4 L$  amidships is to be determined according to the requirements of **Ch 5, Sec 2**.

Table 10.3.1 Section modulus of transverse sections of hull, etc.

Item	Requirement
Section modulus	$Z_1 = \frac{(M_s + M_w)}{\sigma} \times 10^3 \quad (\text{cm}^3)$
Minimum section modulus	$Z_{\min} = C_1 L^2 B (C_b + 0.7) K \quad (\text{cm}^3)$
Minimum moment of inertia	$I_{\min} = 3 C_1 L^3 B (C_b + 0.7) \quad (\text{cm}^4)$

$M_s$  = maximum longitudinal bending moments in still water (kN · m) for sagging and hogging, respectively, which are calculated at the transverse section under consideration along the length of hull for all conceivable loading conditions by a method of calculation deemed appropriate by the Society **[See Guidance]**

$M_w$  = wave induced longitudinal bending moment (kN · m) at the transverse section under consideration along the length of hull, which is to be obtained from the following table

Condition		$M_w$ (kN · m)
$M_s$	Hogging	$0.19 C_1 C_2 L^2 B C_b$
	Sagging	$0.11 C_1 C_2 L^2 B (C_b + 0.7)$

$\sigma$  = allowable bending stress obtained from the following formula

$$\sigma = 175/K \quad (\text{N/mm}^2)$$

$K$  = material factor given by the following table

Steel grades	$K$
A, B, D and E	1.0
AH 32, DH 32 and EH 32	0.78
AH 36, DH 36 and EH 36	0.72
AH 40, DH 40 and EH 40	0.68

$C_1$  = coefficient given by the following formula

$$C_1 = 0.03 L_1 + 5$$

$L_1$  = length of ship (m) specified in Ch 1, 102., or 0.97 times the length of ship (m) on the load line, whichever is the smaller

$C_2$  = distribution factor specified along the length of  $L$  at positions where the transverse section of the hull is under consideration, as given in **Fig 10.3.1**.

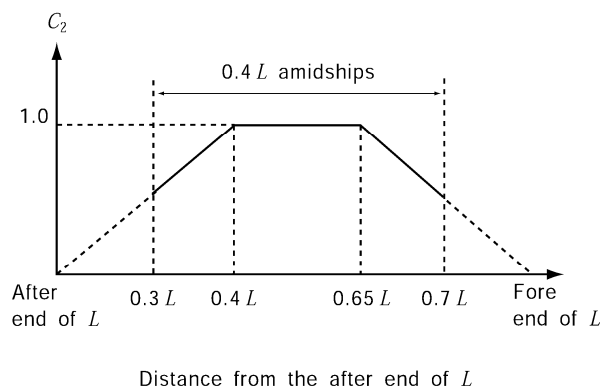

Fig 10.3.1 Distribution factor of bending moment  $C_2$

$C_b$  = block coefficient, however, to be taken as 0.6, where it is less than 0.6

### 203. Calculation of hull section modulus **【See Guidance】**

As for calculation of the hull section modulus, the following (1) through (6) are to be applied:

- (1) All longitudinal members which are considered effective to the longitudinal strength of the ship may be included in the calculation.
- (2) Deck openings on the strength deck are to be deducted from the sectional area used in the section modulus calculation. However, small openings not exceeding 2.5 m in length or 1.2 m in breadth need not be deducted, provided that the sum of their breadths in one transverse section is not more than  $0.06(B - \Sigma b)$ . Where,  $\Sigma b$  is the sum of the openings exceeding 1.2 m in breadths or 2.5 m in length (m).
- (3) Notwithstanding the requirement in (2), deck openings on the strength deck need not be deducted, provided that the sum of their breadths in one transverse section is not reducing the section modulus at deck or bottom by more than 3%.
- (4) Deck openings prescribed in (2) and (3) include shadow area which is obtained by drawing two tangential lines with an opening angle of 30 degrees having the focus on the longitudinal line of the ship.
- (5) The section modulus at the strength deck is to be calculated by dividing the moment of inertia of the athwartship section about its horizontal neutral axis by the following distance (a) or (b), whichever is the greater.
  - (a) Vertical distance from the neutral axis to the top of the strength deck beam at side.
  - (b) Distance obtained from the following formula:

$$Y \left( 0.9 + 0.2 \frac{X}{B} \right)$$

where:

$X$  = horizontal distance from the top of continuous strength member to the centre line of the ship (m)

$Y$  = vertical distance from the neutral axis to the top of continuous strength member (m)

$X$  and  $Y$  are to be measured to the point giving the largest value of the above formula.

- (6) The section modulus at the bottom is to be calculated by dividing the moment of inertia of the athwartship section about its horizontal neutral axis by the vertical distance from the neutral axis to the top of keel.

## Section 3 Buckling Strength

### 301. Compressive buckling strength

The requirements in this Section apply to the strength deck plating and bottom shell plating, etc. subject to large compressive stresses due to longitudinal bending, and only compressive stress is to be considered among the requirements in **Pt 3, Ch 3, Sec 4.** ↓

## CHAPTER 4 PLATE KEELS AND SHELL PLATINGS

### Section 1 General

#### 101. Consideration for corrosion

The thickness of shell plating at such parts that the corrosion is considered excessive due to the location and/or special service condition of the ship is to be properly increased over that required in this Chapter.

#### 102. Special consideration for contact with quay, etc. **【See Guidance】**

In case where the service condition of the ship is considered to be such that there is possibility of indent of shell plating due to contact with the quay, etc., special consideration is to be given to the thickness of shell plating.

#### 103. Continuity in thickness of the shell plating

Sufficient consideration is to be paid to the continuity in the thickness of shell plating and to the avoidance of remarkable difference between the thickness of the shell plating under consideration and that of the adjacent shell plating.

### Section 2 Plate Keels

#### 201. Breadth and thickness

1. The breadth of plate keel over whole length of the ship is not to be less than that obtained from the following formula:

$$b = 4.5L + 775 \text{ (mm)}$$

2. The thickness of plate keel over whole length of the ship is not to be less than the bottom shell thickness obtained from the requirement in **304**, increased by 1.5 mm. This thickness, however, is not to be less than that of the adjacent bottom shell plating.

### Section 3 Shell Plating for Midship Part of Ship

#### 301. Minimum thickness

The minimum thickness of shell plating below the strength deck for the midship part of ship is not to be less than that obtained from the following formula:

$$t = 0.044L + 4.6 \text{ (mm)}$$

#### 302. Thickness of side shell plating

The thickness of side shell plating other than the sheer strake at the strength deck for the midship part of ship is not to be less than that obtained from the following formula:

$$t = 4.1S\sqrt{d + 0.04L} + 1.5 \text{ (mm)}$$

where:

$S$  = spacing of longitudinal or transverse frames (m)

### 303. Sheer strakes for midship part **【See Guidance】**

The thickness of sheer strakes at the strength deck for midship part is not to be less than 0.75 times that of the stringer plate of the strength deck. In no case, however, is the thickness to be less than that of the adjacent side shell plating.

### 304. Thickness of bottom shell plating

The thickness of bottom shell plating including bilge strake (excluding keel plate) for the midship part of ship is not to be less than that obtained from the formulae given in **Table 10.4.1**.

**Table 10.4.1 Thickness of bottom shell plating**

Framing	Thickness (mm)
Transverse	$t = 4.7S\sqrt{d+0.035L} + 1.5$
Longitudinal	$t = 4.0S\sqrt{d+0.035L} + 1.5$
$S$ = spacing of longitudinal or transverse frames (m)	

## Section 4 Shell Plating for End Parts

### 401. Shell plating for end parts **【See Guidance】**

Beyond the midship part, the thickness of shell plating below the strength deck may be gradually reduced, but at the end parts the thickness is not to be less than that obtained from the following formula. However, for the parts specified in **402.** to **405.**, the thickness is not to be less than that required in the respective provisions.

$$t = 0.044L + 4.6 \text{ (mm)}$$

### 402. Shell plating for 0.3L from the fore end

The thickness of shell plating for 0.3L from the fore end is not to be less than that obtained from the following formula:

$$t = 1.34 S\sqrt{L} + 1.5 \text{ (mm)}$$

where:

$S$  = spacing of longitudinal or transverse frames (m)

### 403. Shell plating for 0.3L from the after end

The thickness of shell plating for 0.3L from the after end is not to be less than that obtained from the following formula. In ships with machinery aft or in ships with high power engines, the thickness is to be properly increased:

$$t = 1.20 S\sqrt{L} + 1.5 \text{ (mm)}$$

where:

$S$  = spacing of longitudinal or transverse frames (m)

### 404. Strengthened bottom forward **【See Guidance】**

1. The thickness of shell plating at the strengthened bottom forward specified in **Ch 7, 902.** is to be in accordance with the requirements in **Pt 3, Ch 4, 404.**

2. Notwithstanding the requirement of **Par 1**, in ship of which  $C_b$  is less than 0.7 and  $V/\sqrt{L}$  (kt/m) is 1.4 and over, the area and thickness of shell plating at the strengthened bottom forward of the ship is to be stiffened to an extent in accordance with the discretion of the Society.

**405. Shell plating fitted up on spectacle bossings and stern frames**

The thickness of shell plating fitted up on spectacle bossings and stern frames is not to be less than that obtained from the following formula:

$$t = 0.09L + 3.5 \text{ (mm)}$$

## Section 5 Side Plating in way of Superstructure

**501. Side platings in way of superstructure deck designed as strength deck**

Where the superstructure deck is designed as strength deck, the thickness of superstructure side plating is to be as specified in **301.**, **302.** and **401.** to **403.** However, superstructure side plating at end parts may be of thickness specified in **502.**

**502. Side platings in way of superstructure deck not designed as strength deck**

Where the superstructure deck is not designed as strength deck, the thickness of superstructure side plating is not to be less than obtained from the formulae given in **Table 10.4.2**, but in no case is it to be less than 5.5 mm.

**Table 10.4.2 Thickness of superstructure side plating**

Location	Thickness (mm)
For 0.25 L from the fore end	$t = 1.15S\sqrt{L} + 1.0$
Elsewhere	$t = 0.94S\sqrt{L} + 1.0$
$S$ = spacing of longitudinal or transverse frames (m)	

**503. Compensation at ends of superstructure [See Guidance]**

Side plating at the ends of superstructure is to be suitably constructed to maintain the continuity of strength.

## Section 6 Local Compensation of Shell Plating

**601. Openings in shell [See Guidance]**

All openings in the shell plating are to have well rounded corners and to be compensated as necessary.

**602. Thickness of sea chest [See Guidance]**

In case where a sea chest is provided in the shell plating for sea suction or discharge, the thickness of sea chest is not to be less than obtained from the following formula and to be suitably stiffened so as to provide sufficient rigidity as necessary. The thickness, however, is not to be less than the thickness of shell plating where the sea chest is installed.

$$t = 0.07L + 4.0 \text{ (mm)}$$

**603. Hawse pipes and the plating below**

The shell plating fitted with hawse pipes and the plating below is to be increased in thickness or to be doubled, and their longitudinal seams are to be protected against damages by anchors or cables.

**604. Shell plating framed transversely**

In ships with transverse framing, sufficient consideration is to be paid to the prevention of buckling of the shell. ⚴

## CHAPTER 5 DECKS

### Section 1 General

#### 101. Steel deck plating **【See Guidance】**

Decks are to be plated from side to side of the ship except deck openings, etc. Decks, however, may be provided with only stringer plates and tie plates, subject to the approval by the Society.

#### 102. Watertightness of decks **【See Guidance】**

Weather decks are to be made watertight.

#### 103. Continuity of steps of decks

Where strength decks or effective decks (the decks below the strength deck which are considered as strength members in the longitudinal strength of hull) change in level, the change is to be accomplished by gradual sloping, or each of structural members which form deck is to be extended, and is to be effectively tied together by diaphragms, girders, brackets, etc. and special care is to be taken for the continuity of strength.

#### 104. Compensation for openings **【See Guidance】**

Hatchways or other openings on strength or effective decks are to have well rounded corners, and compensation is to be suitably provided as necessary.

#### 105. Rounded gunwales **【See Guidance】**

Rounded gunwales, where adopted, are to have a sufficient radius for the thickness of plates.

### Section 2 Effective Sectional Area of Strength Deck

#### 201. Definition

The effective sectional area of strength deck is the sectional area, on each side of the ship's centre line, of steel plating, longitudinal beams, longitudinal girders, etc. extending for  $0.5 L$  amidships.

#### 202. Effective sectional area of strength deck **【See Guidance】**

1. The effective sectional area for the midship part is to be so determined as not to give less modulus of athwartship section of the hull specified in **Ch 3**.
2. Beyond the midship part, the effective sectional area may be gradually reduced. However, at  $0.15 L$  from each end it is not to be less than 40 % for ships with machinery amidship and 50 % for ships with machinery aft, of the area required for the midship part.
3. Where the section modulus of the hull at  $0.15 L$  from each end is calculated and approved by the Society, the requirements specified in **Par 2** may not be applied.

#### 203. Strength deck beyond $0.15 L$ from each end

Beyond  $0.15 L$  from each end, the effective sectional area and the thickness of strength deck may be gradually reduced avoiding abrupt change.

#### 204. Long poop **【See Guidance】**

Notwithstanding the requirements of **202.**, the effective sectional area of strength deck within long poop may be properly modified.

### 205. Superstructure deck designed as strength deck **【See Guidance】**

Where the superstructure deck is designed as strength deck, the strength deck plating clear of the superstructure is to extend into the superstructure for about  $0.05L$  without reducing the effective sectional area, and may be gradually reduced within.

## Section 3 Deck Plating

### 301. Thickness

1. The thickness of deck plating is not to be less than obtained from the formula given in **Table 10.5.1**. However, within such enclosed spaces as superstructures, deckhouses, etc., the thickness may be reduced by 1 mm.
2. Where strength deck is transversely framed, or decks inside the line of openings are longitudinally framed, sufficient care is to be taken to prevent buckling of the deck plating.

**Table 10.5.1 Thickness of deck plating**

Kind of deck	Location	Framing	Thickness (mm)
Strength deck	Outside the line of openings for the midship part	Longitudinal	$t = 1.47S\sqrt{h} + 1.5$
		Transverse	$t = 1.63S\sqrt{h} + 1.5$
	Elsewhere	$t = 1.25S\sqrt{h} + 1.5$	
Other deck			

$S$  = spacing of longitudinal or transverse beams (m)  
 $h$  = deck load as specified in Ch 10, 201. (kN/m<sup>2</sup>)

### 302. Thickness of the top of tanks

The thickness of deck plating forming the top of tanks is not to be less than required in **Ch 15, 206**. for deep tank bulkhead plating, taking the beam spacing as the stiffener spacing.

### 303. Thickness of the bulkhead recesses

The thickness of deck plating forming the top of shaft tunnels, thrust recesses or bulkhead recesses is not to be less than required in **Ch 14, 207**. for watertight bulkhead plating, taking the beam spacing as the stiffener spacing.

### 304. Under boilers or refrigerated cargoes

1. The thickness of effective deck plating under boilers is to be increased by 3 mm above the normal thickness.
2. The thickness of deck plating under refrigerated cargoes is to be increased by 1 mm above the normal thickness. Where special means for the protection against the corrosion of the deck is provided, the thickness need not be increased.

### 305. Deck plating carrying unusual cargoes

The thickness of deck plating subject to cargo loads which can not be treated as evenly distributed loads is to be determined taking account of load distribution for particular cargoes. ↓

## CHAPTER 6 SINGLE BOTTOMS

### Section 1 General

#### 101. Application

The requirements in this Chapter apply to ships whose double bottom is omitted partially or wholly in accordance with the requirements in **Ch 7, 101. 3 to 4.**

### Section 2 Centre Keelsons

#### 201. Arrangements and construction

1. All single bottom ships are to have centre girder composed of web plates and face plates, and the centre keelsons are to extend as far forward and afterward as practicable.
2. The bottom constructions in way of fore and after peaks are to be in accordance with the requirements in **Ch 13, Sec 2 and 3.**

#### 202. Web plates

1. The thickness of web plates is not to be less than that obtained from the following formula. Beyond the midship part, the thickness may be gradually reduced and it may be 0.85 times the midship value at the ends of the ship.

$$t = 0.065L + 4.2 \text{ (mm)}$$

2. The height of web plates is not to be less than that of floors.

#### 203. Face plates

1. The thickness of face plates is not to be less than that of web plate amidships and the face plates are to extend from the collision bulkhead to the after peak bulkhead.
2. The sectional area of face plates is not to be less than that obtained from the following formula. Beyond the midship part, the sectional area may be gradually reduced and it may be 0.85 times the midship value at the ends of the ship.

$$A = 0.6L + 9 \text{ (cm}^2\text{)}$$

3. The breadth of face plates is not to be less than that obtained from the following formula:

$$b = 2.3L + 160 \text{ (mm)}$$

### Section 3 Side Keelsons

#### 301. Arrangements

Side keelsons are to be so arranged that their spacing is not more than 2.5 m between the centre keelsons and the side shell plating.

#### 302. Construction

The side keelsons are to be composed of continuous web plates in association with face plates, and they are to extend as far forward and afterward as practicable.

### 303. Web plates

1. The thickness of web plates is not to be less than that obtained from the following formula for the midship part. Beyond the midship part, the thickness may be gradually reduced and it may be 0.85 times the midship value at the ends of the ship.

$$t = 0.042L + 4.8 \text{ (mm)}$$

2. In the engine space, the thickness of web plates is not to be less than that required for the centre keelsons web plates specified in **202**.

### 304. Face plates

The thickness of face plates is not to be less than that required for the web plates, and the sectional area of face plates amidships is not to be less than obtained from the following formula. Beyond the midship part, the sectional area may be gradually reduced and it may be 0.85 times the midship value at the ends of the ship.

$$A = 0.45L + 8.8 \text{ (cm}^2\text{)}$$

## Section 4 Floor Plates

### 401. Arrangements

1. In ships with the bottom of transverse framing, the standard spacing of floors is to comply with the requirements in **Ch 8, 201**.
2. In ships with the bottom of longitudinal framing, floors are to be so arranged that their spacing is not more than about 3.5 m.

### 402. Shapes

1. Upper edges of floor plates at any part are not to be below the level of upper edge at the centre line.
2. In the midship part, the depth of floors measured at a distance  $d_0$  specified in **403. 1** from the inner edge of frames along the upper edge of floors, is not to be less than  $0.5 d_0$ . Where frame brackets are provided, the depth of floors at the inner edge of brackets may be  $0.5 d_0$ . (See **Fig 10.6.1**)
3. In ships having unusually large rise of floor, the depth of floor plates at the centre line is to be suitably increased.
4. Face plates provided on the floor plates are to be continuous from the upper part of bilge at one side to the upper part of bilge on the opposite side in case of curved floors, and extending over the floor plate in case of floors connected by frame brackets.

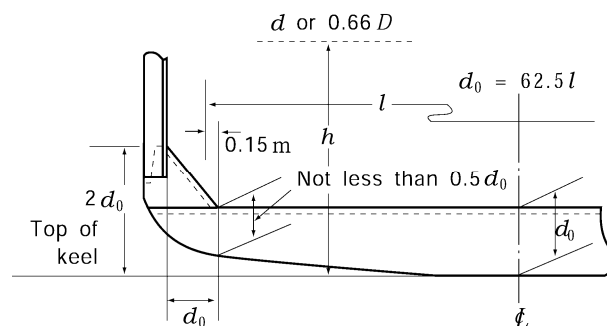

Fig 10.6.1 Shape of floors

#### 403. Scantlings

1. The scantlings of floor plates are not to be less than obtained from the formulae given in **Table 10.6.1**.

**Table 10.6.1 Scantlings of floor plates**

Items	Scantlings	
(1) Depth at the centre line	$d_0 = 62.5l$	(mm)
(2) Thickness	$t^{(1)} = 0.01d_0 + 3$	(mm)
(3) Section modulus	$Z = 4.27 S h l^2$	(cm <sup>3</sup> )
S = spacing of floor (m) h = d or 0.66 D, whichever is the greater (m) l = span between the toes of frame brackets measured at amidship plus 0.3 m, Where curved floors are provided, the length l may be suitably modified, (See Fig 10.6.1).		
(NOTES)		
(1) The thickness of floor plates need not exceed 12 mm		

2. The thickness of face plates on the floor plates is not to be less than that required for the floor plates, and the breadth of face plates is to be adequate for lateral stability of the floors.
3. Beyond 0.5 L amidships, the thickness of floor plates may be gradually reduced and at the end parts of the ship it may be 0.85 time the value specified in **Par 1**, except for the forward flat bottom.
4. Floors under engines and thrust seats are to be of ample depth and to be specially strengthened. Their thickness is not to be less than that of the centre girder web plates.
5. At the strengthened bottom forward specified in **Ch 7, 902**, the depth of floor plates is to be increased, or alternatively, the section modulus of floor plates required by **Par 1** is to be suitably increased.

#### 404. Frame brackets

The scantlings of frame brackets are to be determined in accordance with the requirements of the following. The free edge of the bracket is to be flanged.

- (1) The height of the bracket measured from the top of keel is not to be less than twice the required depth of the floor plate at the centreline of the ship. (See **Fig 10.6.1**)
- (2) The arm of the bracket measured along the upper edge of the floor plate from the inner edge of frame is not to be less than the depth of the floor plate required at the centreline of the ship. (See **Fig 10.6.1**)
- (3) The thickness of frame brackets is not to be less than that of floor plates.

#### 405. Drainage holes

Drainage holes are to be provided on the floor plates on both sides of the centreline and for ships with flat bottom also at the low parts of the turn of bilge.

#### 406. Lightening holes

Lightening holes may be provided in floor plates. Where the holes are provided, appropriate strength compensation is to be made by increasing the floor depth or by some other suitable means.

#### 407. Floor plates forming part of bulkheads

Floor plates forming part of bulkheads are to be in accordance with the requirements in **Ch 14, 15**.

## Section 5 Longitudinals

### 501. Spacing

The standard spacing of bottom longitudinals is obtained from the following formula:

$$S = 2L + 550 \text{ (mm)}$$

### 502. Scantlings

The section modulus of bottom longitudinals is not to be less than that obtained from the following formula:

$$Z_b = 9.Shl^2 \text{ (cm}^3\text{)}$$

where:

$l$  = spacing of solid floors (m)

$S$  = spacing of bottom longitudinals (m)

$h$  = vertical distance from the longitudinals to a point of  $d + 0.026L$  above the top of keel (m)

## Section 6 Strengthened Bottom Forward

### 601. Application

Strengthening of the forward bottom is to be in accordance with the requirements in **Ch 7, Sec 9.**

↓

## CHAPTER 7 DOUBLE BOTTOMS

### Section 1 General

#### 101. Application **【See Guidance】**

1. Passenger ships engaged on international voyages and cargo ships(except tankers) of not less than 500 tons gross tonnage engaged on international voyages, in principle, are to be provided with watertight double bottoms extending from the collision bulkhead to the after peak bulkhead. (2018)
2. Where a double bottom is required to be fitted, the inner bottom is to be continued out to the ship's sides in such a manner as to protect the bottom to the turn of the bilge. And the inner bottom is not to be lower at any part than a plan parallel with the keel line and which is located not less than a vertical distance  $h$  measured from the keel line, as calculated by the formula: (2018)

$$h = B/20$$

$B$  = the greatest moulded breadth in meters of the ship at or below the deepest subdivision draught.

However, in no case is the value of  $h$  to be less than 760 mm, and need not be taken as more than 2,000 mm.

3. Where, for the structural configuration, hull form, purpose etc., it is desired to omit double bottom partially or wholly subject to the approval by the Society. (2018)
4. A double bottom may be omitted in way of watertight tanks, including dry tanks of moderate size subject to the approval by the Society. (2018)
5. The requirements in this Chapter may be suitably modified, where partial double bottoms are provided and where special arrangements such as longitudinal bulkheads or inner skins are made to reduce the unsupported breadth of double bottoms.
6. Where the longitudinal system of framing is transformed into the transverse system, or the depth of double bottom changes suddenly, special care is to be taken for the continuity of strength by means of additional intercostal girders or floors.
7. Bottom structure of holds is to be subjected to special consideration when the hold is intended to carry heavy cargoes or where cargo loads can not be treated as evenly distributed loads.

#### 102. Manholes and lightening holes

1. Manholes and lightening holes are to be provided in all non-watertight members to ensure accessibility and ventilation, except in way of widely spaced pillars and where such openings are not permitted by this rule.
2. The number of manholes in tank tops is to be kept to the minimum compatible with securing free ventilation and ready access to all parts of the double bottom. Care is to be taken for locating the manholes to avoid the possibility of inter connection of main subdivision compartments through the double bottom so far as practicable.
3. Covers of manholes specified in **Par 2** are to be of steel, and where no ceiling is provided in the cargo holds, the covers and their fittings are to be effectively protected against damages by cargoes.
4. Air and drainage holes are to be provided in all non-watertight members of the double bottom structure.
5. The proposed locations and sizes of manholes and lightening holes are to be indicated in the plans submitted for approval.

### 103. Drainage

1. The bilge well in suitable size is to be provided for draining water which may gather on the double bottom.
2. Small wells constructed in the double bottom in connection with drainage arrangements of holds, etc., shall not extend downward more than necessary. A well extending to the outer bottom is, however, permitted at the after end of the shaft tunnel.
3. Other wells (e.g., for lubricating oil under main engines) may be permitted by the Society if satisfied that the arrangements give protection equivalent to that afforded by a double bottom complying with this Chapter. (2018)
4. For wells specified in **Par 2.** and **3.** above, except those at the ends of shaft tunnels, the vertical distance from the bottom of such a well to a plane coinciding with the keel line is not to be less than  $h/2$  or 500 mm, whichever is greater, Where, however, the vertical distance do not meet the requirement, the concerned parts are to be in accordance with the requirements in **Pt 3, Ch 7, 101. 3.** above.

### 104. Cofferdams (2026)

1. A cofferdam means an empty space arranged so that compartments on each side have no common boundary; a cofferdam may be located vertically or horizontally. As a rule, a cofferdam is to be kept gas-tight and is to be properly ventilated, provided with drainage arrangement, and of sufficient size to allow proper inspection, maintenance and safe evacuation.
2. Cofferdams are to be provided between compartments intended for liquid hydrocarbons (including fuel oil, lubricating oil) and those intended for fresh water (water for propelling machinery and boilers) as well as tanks intended for the carriage of liquid foam for fire extinguishing.
3. Furthermore, tanks carrying fresh water for human consumption are to be separated from other tanks containing substances hazardous to human health by cofferdams or other means as approved by the Society. Normally, tanks for fresh water and water ballast are considered non-hazardous.
4. Where a corner to corner situation occurs, tanks are not considered to be adjacent.
5. The cofferdams specified in **Par. 2** may be waived when deemed impracticable or unreasonable by the Society in relation to the characteristics and dimensions of the spaces containing such tanks, provided that the common boundaries have full penetration welds.
6. The cofferdams in **Par. 1** are to be provided with the air pipes to comply with the requirements in **Pt 5, Ch 6, 201** and with the manholes of adequate size which are well accessible.

### 105. Watertight girders and floors

The thickness of watertight girders and floors, and the scantlings of stiffeners attached to them are to comply with the relevant requirements for girders and floors, as well as the requirements in **Ch 15, 202.** and **203.**

### 106. Minimum thickness

No member of the double bottom structure is to be less than 6 mm in thickness.

### 107. Ceilings

1. In ships with double bottoms, close ceilings are to be laid from the margin plate to the upper turn of bilge so arranged as to be readily removable for inspection of the limbers.
2. Ceilings are to be laid on the inner bottoms under hatchways, unless the requirements in **601.** or **Pt 7, Ch 3, 204. 2** of the Rules are applied.
3. Ceilings on the top of double bottom are to be laid on battens not less than 13 mm in thickness. The top plating of tanks, where ceiled directly, is to be covered with good tar put on hot and well sprinkled with cement powder, or with other equally effective coatings.
4. The thickness of ceilings is to be as follows.

$L$	Thickness of ceiling(mm)
$L < 61$ m	50
$61 \text{ m} \leq L \leq 76$ m	57
$L > 76$ m	63

## Section 2 Centre Girders

### 201. Arrangement and construction

- Centre girders are to extend as far forward and afterward as practicable.
- Centre girder plates are to be continuous for  $0.5L$  amidships.
- Where double bottoms are used for carriage of fuel oil or fresh water, the centre girders are to be watertight.
- The requirements in **Par 3** may be suitably modified, in narrow tanks at the end parts of the ship or where other watertight longitudinal divisions are provided at about  $0.25 B$  from the centre line or where deemed appropriate by the Society.

### 202. Lightning holes

- Lightening holes may be provided on centre girders in every frame space outside  $0.75 L$  amidships.
- Lightening holes may be provided on centre girders in alternate frame spaces for  $0.75 L$  amidships, provided that the depth of holes does not exceed one-third of the depth of centre girder.

### 203. Depth

The depth of centre girders is not to be less than  $B/16$  unless specially approved by the Society, but in no case is it to be less than 760 mm.

### 204. Thickness

The thickness of centre girder plates is not to be less than that obtained from the following formula:

$$t = 0.05L + 5 \text{ (mm)}$$

### 205. Brackets

- Where longitudinal framing system is adopted in the double bottom, transverse brackets are to be provided between the solid floors with a spacing not more than about 1.75 m connecting the centre girder plates to the bottom shell plating as well as the adjacent bottom longitudinals. Where the spacing of these brackets exceeds 1.25 m, additional stiffeners are to be provided for the centre girder plates.
- The thickness of the brackets specified in **Par 1** is not to be less than that obtained from the following formula. However, it need not be greater than that of the solid floors at the same location.

$$t = 0.6\sqrt{L} + 1.5 \text{ (mm)}$$

- The strength of stiffeners specified in **Par 1** is not to be less than that of a flat bar having the same thickness as that of girder plates and having the depth not less than  $0.08 d_0$ , where  $d_0$  is the depth of centre girder (mm).

## Section 3 Side Girders

### 301. Arrangement

1. Side girders in  $0.5L$  amidships are to be so arranged that the distance from the centre girder to the first side girder, between girders, or from the outermost girder to the side shell plating does not exceed approximately 4.6 m and to extend as far forward and afterwards as practicable.
2. In the strengthened bottom forward specified in **902.** of ships, side girders and half-height girders are to be provided as required in **903.**
3. Adequate strengthening is to be made under main engines and thrust seatings by means of additional full or half-height girders.

### 302. Thickness

The thickness of side girder plates is not to be less than that obtained from the following formula and in engine room it is to be increased by 1.5 mm.

$$t = 0.65\sqrt{L} + 1.5 \text{ (mm)}$$

### 303. Thickness of half-height girders

The thickness of half-height girders is not to be less than obtained from the formula specified in **302.**

### 304. Scantlings of vertical stiffeners and struts

1. Vertical stiffeners are to be provided to side girders at every open floor, or at a suitable distance if the double bottom is framed longitudinally, and vertical struts are to be provided on half-height girders at every open floor.
2. The strength of vertical stiffeners required by **Par 1** is not to be less than that of a flat bar having the same thickness as that of the girder plates and having the depth not less than  $0.08 d_0$  (mm), where  $d_0$  is the height of side girder (mm).
3. The sectional area of vertical struts required by **Par 1** is not to be less than obtained from the formula in **503.** with necessary modification.

### 305. Lightening holes

Within 10 % of the length of a hold from its end bulkheads, the diameter of lightening holes in the side girder is not to exceed one-third of the depth of girders. This requirement may, however, be modified in a short hold and outside  $0.75L$  amidships and where suitable compensation is made to the girder plate.

## Section 4 Solid Floors

### 401. Arrangements

1. Solid floors are to be provided at a spacing not exceeding about 3.5 m.
2. In addition to complying with the requirements in **Par 1**, solid floors are to be provided at the following locations:
  - (1) At every frame in the main engine room. Solid floors may, however, be provided at alternate frames outside the engine seatings, if the double bottom is framed longitudinally.
  - (2) Under thrust seatings and boiler bearers
  - (3) Under transverse bulkheads
  - (4) At the location specified in **903.**, between the collision bulkhead and the after end of the strengthened bottom forward specified in **902.**

3. Watertight floors are to be so arranged that the subdivision of the double bottom generally corresponds to that of the ship.

#### 402. Thickness

The thickness of solid floors is not to be less than that obtained from the following formulae and in the engine room the thickness is to be increased by 1.5 mm.

In ships with transverse framing :  $t = 0.6\sqrt{L} + 1.5$  (mm)

In ships with longitudinal framing :  $t = 0.7\sqrt{L} + 1.5$  (mm)

#### 403. Vertical stiffeners

1. Vertical stiffeners are to be provided on the solid floors at a suitable spacing in case of the double bottom framed transversely, and at every longitudinal in case of the double bottom framed longitudinally.
2. The vertical stiffeners prescribed in **Par 1** is to be a flat bar having the same thickness as that of the floor plate and the depth not less than  $0.08 d_0$  or the equivalent, where  $d_0$  is the depth of the floor at the point under consideration (mm).

#### 404. Lightening holes

Within  $0.1B$  from side shell plating, the diameter of lightening holes provided in the solid floors in the middle half length of a hold is not to exceed about one-fifth of the depth of floors. This requirement may, however, be suitably modified at the end parts of ship and in exceptionally short holds and where the solid floors are suitably compensated for.

## Section 5 Bottom Longitudinals

#### 501. Spacing

The standard spacing of longitudinals is obtained from the following formula :

$$S = 2L + 550 \text{ (mm)}$$

#### 502. Scantlings **【See Guidance】**

1. The section modulus of bottom longitudinals is not to be less than that obtained from the following formula and in no case is it to be less than  $30 \text{ cm}^3$ .

$$Z_b = CS hl^2 \text{ (cm}^3\text{)}$$

where:

$l$  = spacing of solid floors (m)

$S$  = spacing of longitudinals (m)

$h$  = vertical distance from the longitudinals to a point of  $d + 0.026L$  above the top of keel (m)

$C$  = coefficient given in **Table 10.7.1**

**Table 10.7.1 Coefficient  $C$**

Case		$C$
In case where no strut specified in <b>503.</b> is provided midway between floors		8.6
In case where a strut specified in <b>503.</b> deep tanks is provided midway between floors	Where holds are deep tanks	6.2
	Elsewhere	4.1

- The section modulus of inner bottom longitudinals is not to be less than obtained from the formula in **Par 1** with  $C$  equal to 0.85 times the value specified for bottom longitudinals in the same location. Where vertical struts are not provided to the longitudinals under deep tanks, the section modulus of inner bottom longitudinals is to be as specified in **Ch 15, 203**.

### 503. Vertical struts

- Vertical struts are to be rolled sections other than flat bars or bulb plates and to be well overlapped with the webs of bottom and inner bottom longitudinals.
- The sectional area of the vertical struts is not to be less than that obtained from the following formula:

$$A = 2.2Sbh \text{ (cm}^2\text{)}$$

where:

$S$  = spacing of longitudinals (m)

$b$  = breadth of the area supported by the strut (m) (See **Fig 10.7.1**)

$h$  = as specified in **502. 1**

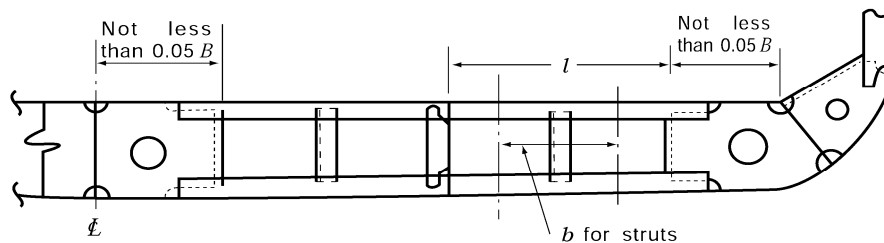

Fig 10.7.1 Open Floors

## Section 6 Inner Bottom Plating and Margin Plates

### 601. Thickness of inner bottom plating [See Guidance]

The thickness of inner bottom plating is not to be less than that obtained from the following formula and the thickness is to be increased by 2 mm in main engine room and under hatchway, if no ceiling is provided:

$$t = 3.8S\sqrt{d} + 1.5 \text{ (mm)}$$

where:

$S$  = spacing of inner bottom longitudinals for longitudinally framed inner bottom plating, or spacing of floor plates for transversely framed inner bottom plating (m)

### 602. Ships handling cargoes regularly by mechanical appliances such as grabs

In ships which regularly handle cargoes by grabs or similar mechanical appliances, the thickness of inner bottom plating is to be increased by 2 mm above that specified in **601.**, unless ceiling is provided.

### 603. Arrangements of margin plates

It is recommended that the margin plates are to be of sufficient height to protect the bottom up to the turn of bilge and for forward  $0.2 L$  from the stem the margin plates are to extend to the ship's sides horizontally as far as practicable.

#### 604. Thickness of margin plates

The thickness of margin plates is to be increased by 1.5 mm above that obtained from the formula in 601.

#### 605. Breadth of margin plates

Margin plates are to be of adequate breadth and to extend well inside from the line of toes of tank side brackets.

#### 606. Brackets

1. Where the double bottom is framed longitudinally, brackets are to be transversely provided at every hold frame extending from the margin plate to the adjacent bottom and inner bottom longitudinals.
2. The thickness of brackets specified in Par 1 is not to be less than that obtained from the formula in 205. 2.

### Section 7 Hold Frame Brackets

#### 701. Tank side brackets

1. The thickness of brackets connecting hold frames to margin plates is to be increased by 1.5 mm above that obtained from the formula in 205. 2.
2. The free edges of brackets are to be stiffened.
3. Where the shape of ship requires exceptionally long brackets, additional stiffness is to be provided by fitting angles longitudinally across the top of flanges, or by other suitable means.

### Section 8 Open Floors

#### 801. Arrangements

Where the double bottom is framed transversely, open floors are to be provided at every hold frame between solid floors in accordance with the requirements in this Section.

#### 802. Scantlings of frames and reverse frames

1. The section modulus of frames is not to be less than that obtained from the following formula and in no case is it to be less than 30 cm<sup>3</sup>.

$$Z_b = CS hl^2 \text{ (cm}^3\text{)}$$

where:

$l$  = distance between the brackets attached to the centre girder and the margin plate (m).

Where side girders are provided,  $l$  is the greatest distance between the vertical stiffeners on side girders and the brackets. (See Fig 10.7.1)

$S$  = spacing of frames (m)

$h$  =  $d + 0.026L$  (m)

$C$  = coefficient given in Table 10.7.2

Table 10.7.2 Coefficient  $C$

Case	$C$	
In case where no vertical strut specified in 803. is provided	6.0	
In case where vertical struts specified in 803. are provided	Under deep tanks	4.4
	Elsewhere	2.9

- The section modulus of reverse frames is not to be less than that obtained from the formula in **Par 1** with  $C$  equal to 0.85 times the value specified for frames at the same location. Where no vertical strut is provided to the open floors under deep tanks,  $C$  is to be the value as specified in **Ch 15, 203**.

### 803. Vertical struts

- Vertical struts are to be rolled sections other than flat bars and bulb plates and to be well overlapped with the webs of frames and reverse frames.
- The sectional area of vertical struts is not to be less than that specified in **503**, with necessary modifications.

### 804. Brackets

- Frames and reverse frames are to be connected to the centre girder and margin plates by brackets of not less thickness than obtained from the formula in **205. 2**.
- The breadth of brackets specified in **Par 1** is not to be less than  $0.05 B$  and the brackets are to be well overlapped with frames and reverse frames. The free edges of brackets are to be properly stiffened.

## Section 9 Construction of Strengthened Bottom Forward

### 901. Application 【See Guidance】

- The requirements in this Section are framed for ships having the minimum bow draught not more than  $0.037 L$  at the ballast condition.
- Notwithstanding the requirement in **Par 1**, in ships of which  $C_b$  is less than 0.7 and  $V/\sqrt{L}$  (kt/m) is 1.4 and over, the area of strengthened bottom forward of ship is to be in accordance with the discretion of the Society.

### 902. Strengthened bottom forward 【See Guidance】

- The strengthened bottom forward is the part of the ship's bottom up to a height of  $0.05 d_F$  ( $d_F$  : Bow draught at the ballast condition) from the top of keel at forward from the position specified in **Table 10.7.3**.
- Notwithstanding the requirement of **Par 1**, in case of the ships of which  $C_b$  are especially small, the ships of which the draft in the ballast condition are especially small, and so on, the extent of the strengthened bottom forward is to be extended up to the satisfaction of the Society.

**Table 10.7.3 Range of strengthened bottom forward**

$V/\sqrt{L} (=a)$	Position (from Fore Perpendicular)
$a \leq 1.1$	0.15 L
$1.1 < a \leq 1.25$	0.175 L
$1.25 < a \leq 1.4$	0.2 L
$1.4 < a \leq 1.5$	0.225 L
$1.5 < a \leq 1.6$	0.25 L
$1.6 < a \leq 1.7$	0.275 L
$1.7 < a$	0.3 L

903. Construction

1. Between the collision bulkhead and  $0.05 L$  abaft the after end of strengthened bottom forward, full or half height girders are to be provided in accordance with **Table 10.7.4**. Where transverse framing is adopted between the collision bulkhead and  $0.025 L$  abaft the after end of strengthened bottom forward, half height girders or longitudinals shell stiffeners are to be provided between the side girders.
2. Between the collision bulkhead and the after end of strengthened bottom forward, solid floors are to be provided in accordance with **Table 10.7.4**.

**Table 10.7.4 Construction of strengthened bottom forward**

Double bottom	Members		Side girders	Half-height girders or longitudinals shell stiffeners	Solid floors
	Side				
Transverse framing	Transverse framing	To be provided at intervals within 2.5 m	To be provided between side girders	To be provided at every frame	
	Longitudinal framing			To be provided at intervals within 2.5 m	
Longitudinal framing	Transverse framing		-	To be provided at alternate frames	
	Longitudinal framing			To be provided at intervals within 2.5 m	

3. The solid floors are to be strengthened by fitting vertical stiffeners in way of half-height girders or longitudinal shell stiffeners except where the shell stiffeners are spaced considerably close and the solid floors are adequately strengthened, the vertical stiffeners may be provided on alternate shell stiffeners.
4. Solid floors and side girders are to be adequately stiffened for those ships, of which the minimum bow draught is not less than  $0.025 L$  but not more than  $0.037 L$ , where the construction and arrangement of the strengthened bottom forward are not in accordance with the requirements in **Par 1** and **Par 2**.

904. Scantlings of longitudinal shell stiffeners or bottom longitudinals

The section modulus of longitudinal shell stiffeners or bottom longitudinals in way of the strengthened bottom forward are to be in accordance with **Pt 3, Ch 7, 804**. ↓

## CHAPTER 8 FRAMES

### Section 1 General

#### 101. Application

The requirements in this Chapter apply to ships having transverse strength due to bulkheads not less effective than that specified in **Ch 14**. Where the transverse strength due to bulkheads is not sufficient or hold length is over 25 m in length, additional stiffening is to be made by means of increasing scantlings of frames, provision of web frames, etc.

#### 102. Frames in way of deep tanks

The strength of frames in way of deep tanks is not to be less than that required for stiffeners on deep tank bulkheads.

#### 103. Frames in way of tank tops

Frames are not to extend through the tops of tanks, unless the effective watertight or oiltight arrangements are specially submitted and approved.

#### 104. Frames in boiler spaces and in way of bossing

1. In boiler spaces, the scantlings of frames and side stringers are to be appropriately increased.
2. The construction and scantlings of frames in way of bossing are to be to the satisfaction of the Society. **[See Guidance]**

### Section 2 Frame Spacing

#### 201. Transverse frame spacing

1. The standard spacing of transverse frame is obtained from the following formula:

$$S = 2L + 450 \text{ (mm)}$$

2. Transverse frame spacing in peaks or cruiser sterns as well as between  $0.2L$  from the fore end and the collision bulkhead is not to exceed 610 mm or the standard spacing specified in **Par 1**, whichever is the smaller.
3. The requirements in **Par 2** may be modified, where structural arrangement or scantlings are suitably considered.

#### 202. Longitudinal frame spacing

The standard spacing of longitudinal frames is to be obtained from the following formula:

$$S = 2L + 550 \text{ (mm)}$$

#### 203. Consideration for frame spacing exceeding the standard

Where the spacing of frames is equal to or above the spacing of 170 mm greater than the standard spacing in **201.** and **202.**, the scantlings and structural arrangement of single and double bottoms and of other relevant structures are to be specially considered.

## Section 3 Transverse Hold Frames

### 301. Application

1. Transverse hold frame is the frame provided below the lowest deck from the collision bulkhead to the after peak bulkhead, including the machinery space.
2. The transverse hold frames of ships which have hopper side tanks, top side tanks, or which have a special construction such as inner hulls, will be specially considered. **【See Guidance】**

### 302. Scantlings of transverse hold frames **【See Guidance】**

1. The section modulus of transverse hold frames is not to be less than obtained from the formulae given in **Table 10.8.1**, but in no case is it to be less than 30 cm<sup>3</sup>.

**Table 10.8.1 Section modulus**

Location	Section modulus (cm <sup>3</sup> )
(1) Between 0.15 $L$ from the fore end and the after peak bulkhead	$Z = 2.6Shl^2$
(2) Between 0.15 $L$ from the fore end and the collision bulkhead	$Z = 3.4Shl^2$
(3) For the frames under transverse web beams supporting deck longitudinals	$Z = 2.4n \left\{ 0.17 + \frac{1}{9.81} \cdot \frac{h_1}{h} \cdot \left( \frac{l_1}{l} \right)^2 - 0.1 \frac{l}{h} \right\} Shl^2$
$S$ = frame spacing (m) $l$ = vertical distance from the top of inner bottom plating or single bottom floors at side to the top of deck beams above the frames (m) $h$ = vertical distance from the lower end of $l$ at the place of measurement to a point of $d + 0.044L - 0.54$ above the top of keel (m) $n$ = ratio of the transverse web beam spacing to the frame spacing $h_1$ = deck load stipulated in Ch 10, Sec 2 for the deck beam at the top of frame (kN/m <sup>2</sup> ) $l_1$ = total length of the transverse web beam (m)	

2. Where the depth of bottom centre girder is less than  $B/16$ , the scantlings of frames are to be suitably increased.

### 303. Connection

1. Transverse hold frames are to be overlapped with tank side brackets by at least 1.5 times the depth of frame sections and are to be effectively connected thereto.
2. The upper end of transverse hold frame are to be effectively connected by brackets with the deck or deck beams, and where the deck at the top of frames is longitudinally framed, the upper end brackets are to be extended and connected to the deck longitudinals adjacent to the frames.

## Section 4 Side Longitudinals

### 401. Side longitudinals

1. The section modulus of side longitudinals in the midship part below the freeboard deck is not to be less than that obtained from the following formulae, whichever is the greater, but in no case is it to be less than 30 cm<sup>3</sup>.

$$Z_1 = 8.6 S h l^2 \text{ (cm}^3\text{)}$$

$$Z_2 = 2.9 \sqrt{L} S l^2 \text{ (cm}^3\text{)}$$

where:

$S$  = spacing of longitudinals (m)

$l$  = distance between the web frames or between the transverse bulkhead and the web frame including the length of connection (m)

$h$  = vertical distance from the longitudinals to a point of  $d + 0.044L - 0.54$ (m) above the top of keel

2. Beyond the midship part, the section modulus of side longitudinals may be gradually reduced towards the ends of ships, and may be 0.85 times that obtained from the formula in **Par 1** at the ends. However, the section modulus of side longitudinals between  $0.15L$  from the fore end and the collision bulkhead is not to be less than obtained from the formula in **Par 1**.
3. The depth of flat bars used for longitudinals is not to exceed 15 times the thickness of flat bars.
4. Side longitudinals on sheer strakes in midship part are to be, as far as possible, of slenderness ratio not greater than 60.
5. The section modulus of bilge longitudinals need not exceed that of bottom longitudinals.

#### 402. Side transverse

1. The side transverses supporting side longitudinals are to be arranged at an interval not exceeding 4.8m at sections where solid floors are provided.
2. The scantlings of side transverses are not to be less than those obtained from the following formulae:

Depth:  $d = 100l$  (mm) or 2.5 times the depth of slot for the longitudinals, whichever is the greater

Section modulus:  $Z = C_1 S h l^2 \text{ (cm}^3\text{)}$

Thickness of web:  $t = \frac{C_2 S h l}{d_0} + 1.5 \text{ (mm)}$

where:

$S$  = side transverses spacing (m)

$l$  = vertical distance from the top of inner bottom plating or single bottom floors at side to the deck at the top of side transverses. Where, however, there are effective deck transverses,  $l$  may be measured up to the lower surface of such transverses (m).

$d_0$  = depth of side transverses (mm). However, the depth of slots for side longitudinals is to be deducted from the web depth.

$h$  = vertical distance measured from the lower end of  $l$  to a point of  $d + 0.044L - 0.54$ (m) above the top of keel, but in no case is it to be less than  $1.43l$  (m).

$C_1, C_2$  = coefficients as defined in **Table 10.8.2**

**Table 10.8.2 Coefficients  $C_1$  and  $C_2$**

Coefficient	For side transverses abaft $0.15 L$ from the fore end	For side transverses between $0.15 L$ from the fore end and the collision bulkhead.
C1	4.7	6.0
C2	45	58

- Side transverses are to be provided with tripping brackets at an interval of about 3 m and stiffeners are to be provided on the webs at every longitudinal except for the middle part of the span of side transverses where they may be provided at alternate longitudinals.

## Section 5 Tween Deck Frames

### 501. General

- The scantlings of tween deck frames are to be determined in relation to the strength of hold frames, the arrangement and transverse stiffness of bulkheads, etc.
- In the design of tween deck framing, considerations are to be given to the provision of a reasonable degree of continuity in the framing from the bottom to the top of hull in conjunction with hold frames.
- The provisions in this Section are based on the standard structural arrangement so as to maintain transverse stiffness of ships by means of efficient tween deck bulkheads provided above the hold bulkheads or by web frames extended to the top of superstructures at a proper interval.

### 502. Scantlings **[See Guidance]**

- The section modulus of tween deck frames is not to be less than that obtained from the following formula:

$$Z = CSIL \text{ (cm}^3\text{)}$$

where:

$S$  = frame spacing (m)

$l$  = tween deck height (m), but to be taken as 1.8 m where the height is less than 1.8 m for superstructure frames and as 2.15 m where the height is less than 2.15 m for others, respectively.

$C$  = coefficient given in **Table 10.8.3**

**Table 10.8.3 Coefficient  $C$**

Description of tween deck frames	$C$
Superstructure frames (excluding the following two lines)	0.44
Superstructure frames for $0.125 L$ from after end of ship	0.57
Superstructure frames for $0.125 L$ from fore end and cant frames at stern	0.74
Tween deck frames between the freeboard deck and the second deck	0.74
Tween deck frames between the second deck and the third deck	0.89
Tween deck frames between the third deck and the fourth deck	0.97

2. The scantlings of tween deck frames below the free board deck within  $0.125 L$  from the fore and after ends are to be appropriately increased above those given by **Par 1**.
3. Where decks are supported by longitudinal beams and transverse strong beams, the section modulus of tween deck strong frames which support beams is not to be less than that given by **Pars 1** and **2** multiplied by the coefficient obtained from the following formula. In this case, the section modulus of tween deck frames between strong frames is not to be less than 0.85 times that given by **Pars 1** and **2** and the upper ends are to be connected with brackets.

$$C = 0.2n + 1$$

where:

$n$  = number of tween deck frames between web frames

### 503. Special care to tween deck frames **【See Guidance】**

1. Care is to be taken so that the strength and stiffness of framing at the ends of ship may be increased in proportion to the actual unsupported length of frame as well as the vertical height of tween decks.
2. In ships having specially large freeboard, the scantlings of tween deck frames may be properly reduced.

### 504. Superstructure frames

1. Superstructure frames are to be provided at every frame located below.
2. Superstructure frames for four frame spaces at the ends of bridges and of detached superstructures within  $0.5 L$  amidships are not to be less than the section modulus obtained from the formula in **502**. using 0.74 as the coefficient  $C$ .
3. Web frames or partial bulkheads are to be provided above the bulkheads required by **Ch 14** or at other positions such as may be considered necessary to give effective transverse rigidity to the superstructures.

## Section 6 Frames in Both Peaks

### 601. Transverse frames in fore peaks

The section modulus of transverse frames below the freeboard deck forward collision bulkhead is not to be less than that obtained from the following formula, but in no case is it to be less than  $30 \text{ cm}^3$ .

$$Z = 8 S h l^2 \quad (\text{cm}^3)$$

where:

$S$  = web frame spacing (m)

$l$  = distance between the supports of transverses (m), but to be taken as 2 m where the distance is less than 2 m

$h$  = vertical distance from the midpoint of  $l$  to a point of  $0.12 L$  above the top of keel (m)

### 602. Longitudinal frames in fore peaks

The section modulus of longitudinals below the freeboard deck forward collision bulkhead is not to be less than that obtained from the following formula. However, the modulus obtained from the formula is to be increased by 25 % between  $0.05 D$  and  $0.15 D$  from the top of keel and 50 % below

0.05  $D$  from the top of keel.

$$Z = 8Shl^2 \text{ (cm}^3\text{)}$$

where:

$S$ ,  $l$  = as specified in **401**.

$h$  = vertical distance from the longitudinals to a point of 0.12  $L$  above the top of keel (m), but in no case is it to be less than 0.06  $L$  (m)

### 603. Transverse frames in after peaks

The section modulus of transverse frames below the freeboard deck abaft after peak bulkhead is not to be less than that obtained from the following formula, but in no case is it to be less than 30 cm<sup>3</sup>:

$$Z = 8Shl^2 \text{ (cm}^3\text{)}$$

where:

$S$  = web frame spacing (m)

$l$  = as specified in **Table 8.1**, but to be taken as 2 m where the height is less than 2 m

$h$  = vertical distance from the midpoint of  $l$  to a point of  $d + 0.044L - 0.54$  (m) above the top of keel ↓

## CHAPTER 9 CANTILEVER BEAM CONSTRUCTION

### Section 1 Cantilever Beams

#### 101. Construction and scantlings

Cantilever beams are to comply with the requirements in (1) to (7):

- (1) The root depth of cantilever beams measured at the toe of end brackets at side is not to be less than one-fifth of the horizontal distance from the inboard end of cantilever beam to the toe of end bracket at side.
- (2) The depth of cantilever beams may be gradually tapered from the root towards the inboard end where it may be reduced to about a half of the root depth.
- (3) The section modulus of cantilever beams at the toe of end brackets is not be less than obtained from the following formula: (See **Fig 10.9.1**)

$$Z = 7.1 S l_0 \left( \frac{1}{2} b_1 h_1 + b_2 h_2 \right) \quad (\text{cm}^3)$$

where:

$S$  = cantilever beam spacing (m)

$l_0$  = horizontal distance from the inboard end of cantilever beams to the toe of end brackets (m)

$b_1$  = horizontal distance from the inboard end of cantilever beams to the toe of end brackets of beam or transverse deck girder at side (m). Where, however, the deck is framed longitudinally and no deck transverse is provided between the cantilever beams,  $b_1$  is to be taken as  $l_0$ .

$b_2$  = a half of the breadth of hatch opening in the deck supported by the cantilever beams (m)

$h_1$  = deck load stipulated in **Ch 10, Sec 2** for the deck transverses supported by the cantilever beams ( $\text{kN/m}^2$ )

$h_2$  = load on hatch covers of the deck supported by the cantilever beams which is not to be less than obtained from the following (a) to (c), depending on the type of the deck ( $\text{kN/m}^2$ )

- (a) For the weather deck,  $h_2 h_2$  is the deck load stipulated in **Ch 10, 201. 2** for the deck transverses or the maximum design cargo weight on hatches per unit area ( $\text{kN/m}^2$ ), whichever is the greater. In **Ch 10, 201. 2(1)**, the value of  $y$  may be taken as the vertical distance from the load line to the upper edge of hatch coaming. In either case,  $h_2$  is not to be less than  $17.5 (\text{kN/m}^2)$  for hatches at Position I and  $12.8 (\text{kN/m}^2)$  for those at Position II, specified in **Ch 19**, respectively.
- (b) For decks other than the weather deck where ordinary cargoes or stores are intended to be carried,  $h_2$  is the deck load stipulated in **Ch 10, 201. 1**.
- (c) For decks other than those specified in (a) or (b) above,  $h_2$  is the value equals to  $h_1$ .
- (4) The section modulus of cantilever beams may be gradually tapered from the inner edge of end brackets toward the inboard end of cantilever beams, where it may be reduced to 0.60 times that at the inner edge of end brackets.
- (5) The web thickness of cantilever beams is not to be less than obtained from the following formulae, whichever is the greater:

$$t_1 = 9.5 \frac{S \left( \frac{1}{2} b_1 h_1 + b_2 h_2 \right)}{d_c} + 1.5 \quad (\text{mm})$$

$$t_2 = 0.0075 d_c + 0.46 t_1 + 0.5 \quad (\text{mm})$$

where:

$S, b_1, b_2, h_1$  and  $h_2$  = as stipulated in (3). Where, however, the deck is framed longitudinally and no deck transverse is provided between the cantilever beams, a horizontal distance in *metre* from the inboard end of cantilever beams to the section under consideration is to be substituted for  $b_1/2$  in the formula for  $t_1$ .

$d_c$  = depth of the cantilever beams at the section under consideration (mm), However, in the calculation of  $t_1$ , the depth of slots for deck longitudinals, if any, is to be deducted from the depth of cantilever beams. Where the webs are provided with horizontal stiffeners, the divided web depth may be used for  $d_c$  in the formula for  $t_2$ .

(6) Cantilever beams are to be provided with tripping brackets at an interval of about 3 m. Where the breadth of face bars of cantilever beams exceeds 180 mm on either side of the web, the tripping brackets are to support the face bars as well. And stiffeners are to be provided on the webs at every deck longitudinal adjacent to the root of cantilever beams and at alternate longitudinals elsewhere.

(7) Web plates adjacent to the inner edge of end brackets are to be specially reinforced.

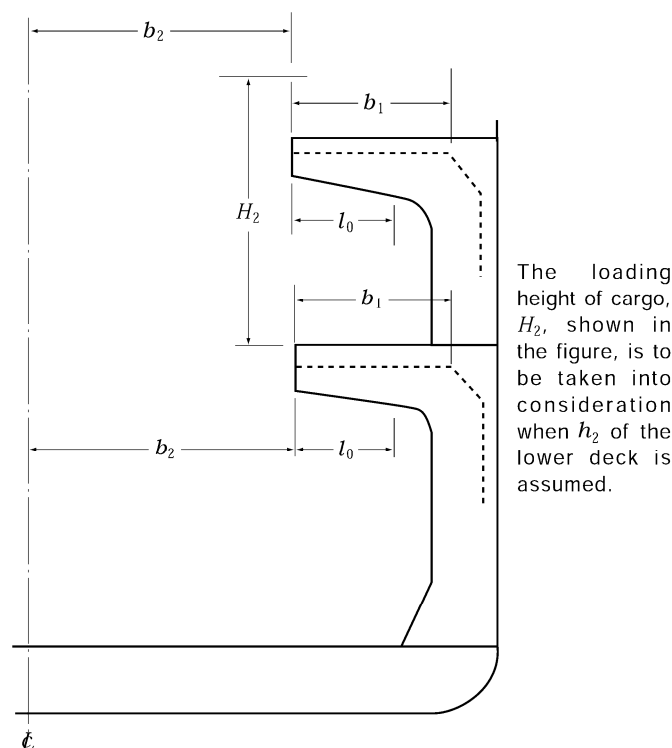

Fig 10.9.1 Measurement of  $l_0, b_1, b_2$ , etc.

## Section 2 Web Frames

### 201. Construction and scantlings

Web frames supporting cantilever beams are to comply with the requirements in (1) to (7):

- (1) The depth of web frames is not to be less than one-eighth of the length including the length of connections at both ends.
- (2) The section modulus is not to be less than that obtained from the following formula. Where, however, a tween deck web frame in association with cantilever beam supporting the deck above is provided at the top of web frame, the value of the formula may be reduced to 60 %.

$$Z = 7.1 S l_1 \left( \frac{1}{2} b_1 h_1 + b_2 h_2 \right) \text{ (cm}^3\text{)}$$

where:

$S$  = web frame spacing (m)

$l_1$  = horizontal distance from the end of supported cantilever beams to the inside of web frames (m)

$b_1, b_2, h_1$  and  $h_2$  = as stipulated in **101. (3)** for the supported cantilever beams. Where, however, the deck is framed longitudinally and no deck transverse is provided between the cantilever beams,  $l_1$  is to be substituted for  $b_1$ .

- (3) The section modulus of tween deck web frames is to be in accordance with the requirements in (2), and additionally, it is not to be less than that obtained from the following formula:

$$Z = 7.1 C_1 S l_1 \left( \frac{1}{2} b_1 h_1 + b_2 h_2 \right) \text{ (cm}^3\text{)}$$

where:

$S, l_1, b_1, b_2, h_1$  and  $h_2$  = as stipulated in (2)

$C_1$  = coefficient obtained from the following formula:

$$C_1 = 0.5 \left( \frac{\frac{1}{2} b'_1 h'_1 + b'_2 h'_2}{\frac{1}{2} b_1 h_1 + b_2 h_2} \right) + 0.15$$

$b'_1, b'_2, h'_1$  and  $h'_2$  =  $b_1, b_2, h_1$  and  $h_2$  respectively stipulated in (2) in respect of cantilever beams to be provided below the web frames concerned.

- (4) The web thickness is not to be less than that obtained from the following formulae, whichever is the greater:

$$t_1 = 9.5 \frac{C_2 S \left( \frac{1}{2} b_1 h_1 + b_2 h_2 \right)}{d_w} \cdot \frac{l_1}{l} + 1.5 \text{ (mm)}$$

$$t_2 = 0.0075 d_w + 0.46 t_1 + 0.5 \text{ (mm)}$$

where:

$S, b_1, b_2, h_1, h_2$  and  $l_1$  = as stipulated in (2)

$d_w$  = the smallest depth of web frames (mm). However, in the calculation of  $t_1$ , the depth of slots for side longitudinals, if any, is to be deducted from the web depth. Where the depth of webs is divided by vertical stiffeners, in the calculation of  $t_2$ , the divided depth may be used for  $d_w$ .

$l$  = length of web frames including the length of connections at the both ends (m)

$C_2$  = coefficient given in **Table 10.9.1**, where, however,  $C_1$  is as specified in (3)

**Table 10.9.1 Coefficient  $C_2$**

Location		$C_2$
For hold web frames	Where web frame in association with cantilever beam supporting the deck above is provided at the top of them	0.9
	Elsewhere	1.5
For tween deck web frames		$C_1 + 0.6$

(5) Where the web frames supporting cantilever beams also support side longitudinals or side stringers, their scantlings are to comply with the following requirements in addition to those in Ch 8, 402.

(a) The section modulus is not to be less than that obtained from the formula in (2), in which is to be multiplied by the following coefficient:

Where tween deck web frame together with cantilever beam is provided above:

$$\alpha = 9.81 \left\{ \frac{0.05hl^2 + 0.09 h_u l_u^2}{1.4 \left( \frac{1}{2} b_1 h_1 + b_2 h_2 \right) l_1} \right\} + 0.6$$

Elsewhere:  $\alpha = 1.0$

where:

$l$  = length of hold web frames including the length of end connections (m)

$l_u$  = length of tween deck web frames provided directly above, including the length of end connections (m)

$h$  = vertical distance from the middle of  $l$  to a point of  $d + 0.038L$  above the top of keel (m)

$h_u$  = vertical distance from the middle of  $l_u$  to a point to which  $h$  is to be measured (m). However, in case where the point is below the middle of  $l_u$ ,  $h_u$  is to be taken as zero.

$b_1, b_2, h_1, h_2$  and  $l_1$  = as given by (2)

(b) The web thickness is not to be less than that given by (4), in which the value of  $t_1$  is to be increased by the amount obtained from the following formula:

$$\beta = 30 \frac{Shl}{d_w} \text{ (mm)}$$

where:

$S$  = web frame spacing (m)

$h, l$  = as stipulated in (a) above

$d_w$  = as stipulated in (4)

(6) Tripping brackets are to be provided on the webs at an interval of about 3 m and stiffeners are to be provided at every side longitudinal at the ends of frames and at alternate longitudinals elsewhere.

(7) The web frames are to be effectively connected with those located beneath or solid floors so as to maintain strength continuity.

### Section 3 Connection of Cantilever Beams to Web Frames

#### 301. Connections [See Guidance]

Cantilever beams and their supporting web frames are to be effectively connected by brackets to meet the requirements in (1) to (4).

(1) The radius of curvature of the free edges of brackets is not to be less than the depth of cantilever beams at the toe of brackets.

(2) The thickness of brackets is not to be less than that of webs of cantilever beams or web frames, whichever is the greater.

(3) The brackets are to be sufficiently strengthened by stiffeners.

(4) The free edges of brackets are to have face bars of a sectional area not less than that of cantilever beams or web frames, whichever is the greater, and the face bars are to be connected with those of cantilever beams and web frames. ↓

## CHAPTER 10 BEAMS

### Section 1 General

#### 101. Standard camber

The standard camber of weather decks is  $0.02 B$  at midship.

#### 102. Connections of ends of beams [See Guidance]

1. Longitudinal beams are to be continuous or to be connected with brackets at their ends in such a manner as to effectively develop the sectional area and to have sufficient strength to bending and tension.
2. Transverse beams are to be connected to frames by brackets.
3. Transverse beams provided at positions where frames are omitted in tween decks or superstructures, are to be connected to the side plating by brackets.
4. Transverse beams on boat decks, promenade decks, etc. may be connected by clips at their ends.

#### 103. Continuity of strength

In parts where longitudinal beams are transformed to transverse beams, special care is to be taken to keep the continuity of strength.

### Section 2 Deck Load

#### 201. Value of $h$ [See Guidance]

1. Deck load  $h$  (kN/m<sup>2</sup>) for decks intended to carry ordinary cargoes or stores is to be in accordance with the following (1) through (3):
  - (1)  $h$  is to be equivalent to the standards given by 7 times the tween deck height at side of the space (m), or 7 times the height from the deck concerned to the upper edge of hatch coaming of the above deck (m). However,  $h$  may be specified as the maximum design cargo weight per unit area of deck (kN/m<sup>2</sup>). In this case, the value of  $h$  is to be determined by considering the loading height of cargo.
  - (2) Where timber and/or other cargoes are intended to be carried on the weather deck,  $h$  is to be the maximum design cargo weight per unit area of deck (kN/m<sup>2</sup>), or the value specified in **Par 2**, whichever is the greater.
  - (3) Where cargoes are suspended from the deck beams or deck machinery is installed,  $h$  is to be suitably increased.
2. Deck load  $h$  (kN/m<sup>2</sup>) for the weather deck is to be as specified in the following (1) to (4):
  - (1) For the freeboard decks, superstructure deck and top of deckhouses on the freeboard deck,  $h$  is not to be less than that obtained from the following formula:

$$h = a(0.067bL - y) \quad (\text{kN/m}^2)$$

where:

- $a$ ,  $b$  = as given by **Table 10.10.1** according to the position of decks. However, where  $C_b$  is less than 0.7, value of  $b$  will be specially considered.
- $y$  = vertical distance from the load line to the weather deck at side (m), and  $y$  is to be measured at fore end for deck forward of  $0.15 L$  abaft the fore end; at  $0.15 L$  abaft the fore end for deck between  $0.3 L$  and  $0.15 L$  abaft the fore end; at midship for deck between  $0.3 L$  abaft the fore end and  $0.2 L$  afore the aft end; and at aft end for deck afterward of  $0.2 L$  afore the aft end. (See **Fig 10.10.1**)

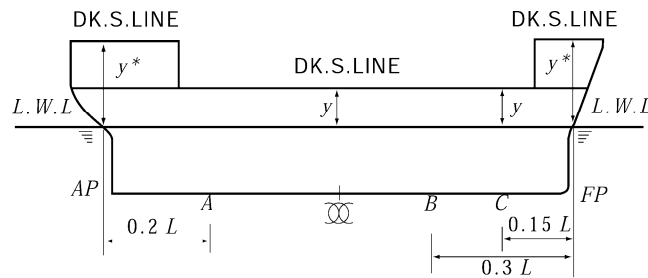

\* In case of no superstructure,  $y$  is the distance to the upper deck.

Abaft A  $y$  is measured at AP  
 Between A and B  $y$  is measured at  $\odot$   
 Between B and C  $y$  is measured at C  
 Afore C  $y$  is measured at FP

Fig 10.10.1 Position of measuring  $y$

- (2)  $h$  for deck given in Column II in **Table 10.10.2** need not exceed that in Column I.
- (3) Notwithstanding the provision in (1) and (2),  $h$  is not to be less than that obtained from the formulae given by **Table 10.10.2**, but to be taken as 12.8 where  $h$  is less than 12.8.
- (4) Value of  $h$  is to be in accordance with the discretion of the Society, where the ship has an unusual large freeboard. **[See Guidance]**

Table 10.10.1 Values of  $a$  and  $b$

Column	Position of Deck	a				b
		Deck plating	Beams	Pillars	Deck girders	
I	Forward of 0.15 L abaft the fore end	14.7	9.80	4.90	7.35	1.42
II	Between 0.15 L and 0.3 L abaft the fore end	11.8	7.85	3.90	5.90	1.20
III	Between 0.3 L abaft the fore end and 0.2 L afore the aft end	6.90	4.60	2.25	2.25 <sup>(1)</sup> , 3.45 <sup>(2)</sup>	1.00
IV	Afterward of 0.2L afore the aft end	9.80	6.60	3.25	4.90	1.15

(NOTES)  
 (1) In case of longitudinal deck girders outside the line of hatchway opening of the strength deck in midship part of ship  
 (2) In case of deck girders other than (1)

Table 10.10.2 Minimum value of  $h$

Column	Position of Deck	$h$	C		
			Beams	Pillars, Longitudinal and transverse deck girders	Deck Plating
I and II	Forward of 0.3 L abaft the fore end	$C\sqrt{L+50}$	2.85	1.37	4.20
III	Between 0.3 L abaft the fore end and 0.2 L afore the aft end		1.37	1.18	2.05
IV	Afterward of 0.2 L afore the aft end	$C\sqrt{L}$	1.95	1.47	2.95
Second tier superstructure deck above the freeboard deck			1.28	0.69	1.95

3. Deck loads  $h$  (kN/m<sup>2</sup>) on non-exposed decks and platforms are to be defined by the designer without being less than 3.0 (kN/m<sup>2</sup>) for accommodation decks and 10.0 (kN/m<sup>2</sup>) for other decks and platforms.

## Section 3 Longitudinal Beams

### 301. Spacing

The standard spacing of the longitudinal beams is obtained from the following formula:

$$S = 2L + 550 \text{ (mm)}$$

### 302. Proportion

1. Longitudinal beams are to be supported by deck transverses of appropriate spacing. In midship part of the strength deck, the slenderness ratio of deck longitudinals is not to exceed 60. This requirement may, however, be suitably modified where longitudinal beams are given a sufficient strength to prevent buckling.
2. Flat bars used for longitudinals are not to be of depth thickness ratio exceeding 15.

### 303. section modulus **【See Guidance】**

1. The section modulus of longitudinal beams outside the line of openings of the strength deck for the midship part is not to be less than that obtained from the following formula:

$$Z = 1.14 S h l^2 \text{ (cm}^3\text{)}$$

where:

$S$  = spacing of longitudinal beams (m)

$h$  = deck load specified in **Sec 2** (kN/m<sup>2</sup>)

$l$  = horizontal distance between bulkhead and deck transverse or between deck transverses (m)

2. The section modulus of longitudinal beams outside the line of openings of the strength deck at 0.1  $L$  of fore end and after end of ship is not to be less than that obtained following formula:

$$Z = 0.43 S h l^2 \text{ (cm}^3\text{)}$$

where:

$S, h, l$  = as specified in **Par 1**

3. The section modulus of longitudinal beams outside the line of openings of the strength deck for the parts forward and afterward midship part of ship may be gradually reduced section modulus by **Par 1**. In no case, however, is the section modulus to be less than obtained from **Par 2** at 0.1  $L$  of fore end and after end of ship.
4. The section modulus of longitudinal beams for the parts other than stipulated in **Pars 1** and **2** is not to be less than obtained from the formula in **Par 2**.

### 304. Deck transverses

In single deck ships, the deck transverses are to be provided in line with the solid floors in double bottom, and in two deck ships, the transverses are also to be provided in line with the solid floors in double bottoms as far as practicable.

## Section 4 Transverse Beams

### 401. Arrangements

Transverse beams are to be provided on every frame.

### 402. Proportion **【See Guidance】**

It is preferable that the length depth ratio of transverse beams be 30 or less at the strength deck, and 40 or less at effective decks (the decks below the strength deck which are considered as strength members in the longitudinal strength of hull) and superstructure decks as far as practicable.

### 403. Section modulus

The section modulus of transverse beams is not to be less than that obtained from the following formula:

$$Z = 0.43 S h l^2 \text{ (cm}^3\text{)}$$

where:

$S$  = spacing of transverse beams (m)

$h$  = deck load specified in **Sec 2** (kN/m<sup>2</sup>)

$l$  = horizontal distance from the inner edge of beam brackets to the longitudinal deck girder, or between the longitudinal deck girders (m)

## Section 5 Beams on Bulkhead Recesses and Others

### 501. Section modulus

The section modulus of beams at deck forming the top of bulkhead recesses, tunnels and tunnel recesses is not to be less than that obtained from the formula in **Ch 14, 207**.

## Section 6 Beams on the Top of Deep Tanks

### 601. Section modulus

The section modulus of beams at deck forming the top of deep tanks is to be in accordance with this Chapter, and not to be less than that obtained from the formula in **Ch 15, 203.**, taking the top of deck beams as the lower end of  $h$  and beams as stiffeners.

## Section 7 Deck Beams Supporting Specially Heavy Loads

### 701. Reinforcement of deck beams

The deck beams supporting specially heavy loads or arranged at the ends of superstructures or deckhouses, in way of masts, windlasses and auxiliary machinery, etc. are to be properly reinforced by increasing the scantlings of beams, or by the additional deck girders or pillars.

## Section 8 Beams on Deck Carrying Unusual Cargoes

### 801. Section modulus of beams

The section modulus of beams on deck subject to cargo loads which can not be treated as evenly distributed loads is to be determined taking account of load distribution for particular cargoes. ↓

## CHAPTER 11 DECK GIRDERS

### Section 1 General

#### 101. Application

Transverse deck girders supporting longitudinal deck beams and longitudinal deck girders supporting transverse deck beams are to be in accordance with the requirements in this Chapter.

#### 102. Arrangement

In way of the bulkhead recesses and the top of tanks, deck girders are to be arranged at an interval not exceeding 4.6 m as far as practicable.

#### 103. Construction **【See Guidance】**

1. Deck girders are to be composed of face plates provided along the lower edge.
2. Tripping brackets are to be provided at an interval of about 3 m and where the breadth of face plates exceeds 180 mm on either side of the girder, these brackets are to be so arranged as to support the face plates as well.
3. The thickness of face plates forming girders is not to be less than that of web plates and the width of the face plates is not to be less than that obtained from the following formula:

$$b = 2.7\sqrt{d_0 l} \quad (\text{mm})$$

where:

$d_0$  = depth of webs (mm)

$l$  = distance between the supports of girders (m). Where, however, effective tripping brackets are provided, they may be taken as supports.

4. The depth of girders is more than 2.5 times that of slots for beams, and is to be kept constant between two adjacent bulkheads for the longitudinal girders.
5. The girders are to have a sufficient rigidity to prevent excessive deflection of decks and excessive additional stresses in deck beams.

#### 104. End connection **【See Guidance】**

1. End connections of deck girders are to be in accordance with the requirements in **Ch 1, 304**.
2. Bulkhead stiffeners or girders at the ends of deck girders are to be suitably strengthened to support deck girders.
3. Longitudinal deck girders are to be continuous or to be effectively connected so as to maintain the continuity at the ends.

### Section 2 Longitudinal Deck Girders

#### 201. Section modulus **【See Guidance】**

1. The section modulus of longitudinal deck girders outside the lines of hatchway opening of the strength deck for midship part is not to be less than that obtained from the following formula:

$$Z = 1.29l (bhl + k W) \quad (\text{cm}^3)$$

where:

- $l$  = distance between the centres of pillars or from the centre of pillar to the bulkhead (m).  
 Where the deck girder is effectively bracketed to bulkhead,  $l$  may be modified as specified in **Ch 1, 306**. (See **Fig 10.11.1**)
- $b$  = distance between the centres of two adjacent spans of beams supported by the girders or the frames (m). (See **Fig 10.11.1**)
- $h$  = deck load specified in **Ch 10, Sec 2** for the deck supported ( $\text{kN/m}^2$ )
- $W$  = deck load supported by the tween deck pillar (kN)
- $k$  = as specified in the following (a) and (b):
  - (a) Coefficient obtained from the following formula according to the ratio of the horizontal distance from the pillar or bulkhead supporting the deck girder to the tween deck pillar  $a$  (m) and  $l$  (See **Fig 10.11.1**)

$$k = 12 \frac{a}{l} \left(1 - \frac{a}{l}\right)^2$$

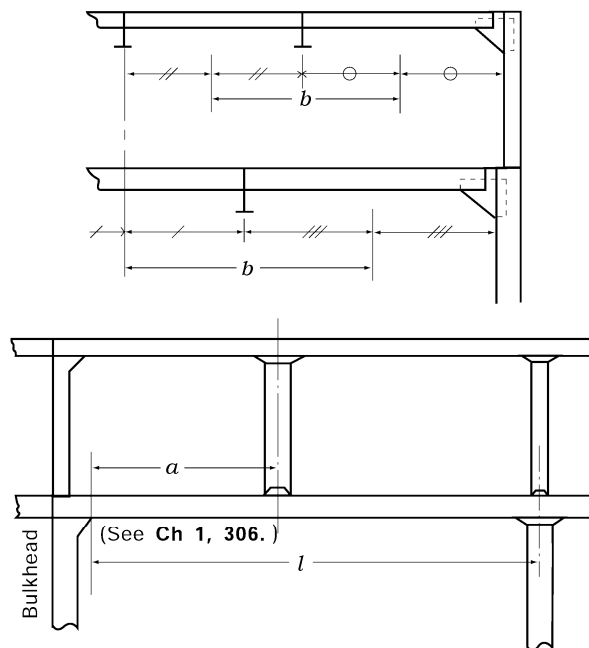

**Fig 10.11.1 Measurement of  $b$ ,  $l$  and  $a$**

- (b) Where there is only one tween deck pillar,  $k$  is to be obtained basing upon the smaller value of  $a$ . Where there are two or more tween deck pillars,  $a$  is to be measured from the same end of  $l$  for each tween deck pillar, and the sum of  $kW$  is to be used for the computation of the formula. In this case, the greater value between the sums of  $kW$  obtained basing upon  $a$  measured from each end of  $l$  is to be used.
2. The section modulus of longitudinal deck girders outside the lines of hatchway opening of the strength deck for the parts forward and afterward the midship part may be gradually reduced. In no case, however, is the section modulus to be less than that obtained from the following formula:

$$Z = 0.484l (bhl + kW) \quad (\text{cm}^3)$$

where:  $b, h, l, W, k$  = as specified in **Par 1**

3. The section modulus of longitudinal deck girders for the parts other than stipulated in **Par 1** and **Par**

2 is not to be less than obtained from the formula in **Par 2**.

4. Where a deck carrying cargoes which loads can not be treated as evenly distributed loads, deck load supported by a pillar is to be determined taking account of load distribution for particular cargoes. Where cargo loads can be treated as concentrated loads acting on specific points, the provisions of **Par 1** to **Par 3** above may be applied so that such concentrated loads ( $W$ ) are treated as deck loads supported by the upper tween deck pillar.

### 202. Moment of inertia

It is advised that the moment of inertia of girders is not to be less than obtained from the following formula:

$$I = CZl \text{ (cm}^4\text{)}$$

where:

$C$  = coefficient obtained from the following:

For deck girders arranged outside the line of deck openings of strength deck of midship part of ship .....	1.6
For other deck girders .....	4.2

$Z$  = required section modulus of girders specified in **201**. (cm<sup>3</sup>)

$l$  = as specified in **201. 1**

### 203. Thickness of web plates

1. The thickness of web plates is not to be less than that obtained from the following formula:

$$t = 10S_1 + 1.5 \text{ (mm)}$$

where:

$S_1$  = spacing of web stiffeners or depth of girders, whichever is the smaller (m)

2. The thickness of web plates at both end parts for  $0.2l$  is not to be less than that specified in **Par 1** and obtained from the following formula, whichever is the greater:

$$t = \frac{4.43bhl}{d_0} + 1.5 \text{ (mm)}$$

where:

$d_0$  = depth of webs (mm)

$b, h, l$  = as specified in **201. 1**

3. The thickness of web plates provided in the deep tanks is to be 1 mm thicker than those obtained from the formulae in **Par 1** and **Par 2**.

## Section 3 Transverse Deck Girders

### 301. Section modulus

1. The section modulus of transverse deck girders is not to be less than that obtained from the following formula:

$$Z = 0.484l (bhl + kW) \text{ (cm}^3\text{)}$$

where:

$l$  = distance between the centres of pillars or from the centre of pillar to the inner edge of beam bracket (m)

$b$  = distance between the centres of two adjacent girders or bulkhead (m)

$h$  = deck load specified in **Ch 10, Sec 2** (kN/m<sup>2</sup>)

$W, k$  = in accordance with **201**.

2. Where a deck carrying cargoes which loads can not be treated as evenly distributed loads, deck load supported by a pillar is to be determined taking account of load distribution for particular cargoes. Where cargo loads can be treated as concentrated loads acting on specific points, the provisions of **Par 1** above may be applied so that such concentrated loads ( $W$ ) are treated as deck loads supported by the upper tween deck pillar.

### 302. Moment of inertia

It is advised that the moment of inertia of girders is not to be less than that obtained from the following formula:

$$I = 4.2Zl \text{ (cm}^4\text{)}$$

where:

$Z$  = required section modulus of girders specified in **301**. (cm<sup>3</sup>)

$l$  = as specified in **301**.

### 303. Thickness of web plates

The thickness of web plates is to be in accordance with the requirements in **203**.

## Section 4 Deck Girders in Tanks

### 401. Section modulus

The section modulus of deck girders in tanks is to be in accordance with the requirements in **201**, or **301**., and is to be in compliance with the requirements in **Ch 15, 204. 1** as well.

### 402. Moment of inertia

The moment of inertia of girders is to be in accordance with the requirement in **Ch 15, 204. 2**.

### 403. Thickness of web plates

The thickness of web plates is to be in accordance with the requirements in **203**, or **303**, and is to be in compliance with the requirements in **Ch 15, 204. 3** as well.

## Section 5 Hatch Side Girders

### 501. Deep coamings on decks

Where deep coamings are provided on decks as in the case of hatchway on weather deck, the horizontal coaming stiffener and the coaming up to its stiffener may be included in the calculation of the section modulus, subject to the approval by the Society.

### 502. Strength continuity

At hatchway corners, the face plates of hatch coamings and longitudinal deck girders or their extension parts and the face plates on both sides of hatch end girders are to be effectively connected so as to maintain the strength continuity.

---

## Section 6 Hatch End Girders

### 601. Scantling

The scantlings of hatch end girders are to be in accordance with the requirements in **Sec 3** and **Sec 4**. ↓

## CHAPTER 12 PILLARS

### Section 1 General

#### 101. Pillars in tween decks

Pillars in tween decks are to be arranged directly above those under the deck, or effective means are to be provided for transmitting their loads to the supports below.

#### 102. Pillars in holds **【See Guidance】**

Pillars in holds are to be provided in line with the keelsons or double bottom girders or as close thereto as practicable, and the structure under pillars is to be of ample strength to provide effective distribution of the load.

#### 103. End connection of pillars

The head and heel of pillars are to be secured by thick doubling plates and brackets as necessary. Where the pillars which may be subjected to tensile loads such as under bulkhead recesses, tunnel tops or deep tank tops, the head and heel of pillars are to be efficiently secured to withstand the tensile loads.

#### 104. Reinforcements

Where the pillars are connected to the deck plating, the top of shaft tunnels, or the frames, these structures are to be efficiently strengthened.

### Section 2 Scantling of Pillars

#### 201. Sectional area **【See Guidance】**

1. The sectional area of pillars is not to be less than that obtained from the following formula:

$$A = \frac{0.223 W}{2.72 - \frac{l}{k_0}} \quad (\text{cm}^2)$$

where:

$l$  = distance from the top of inner bottom, deck or other structures on which the pillars are based to the underside of beam or girder supported by the pillars (m). (See **Fig 10.12.1**)

$k_0$  = minimum radius of gyration of the section of pillars (cm)

$W$  = deck load (kN) supported by the pillar obtained from the following formula:

$$W = k w_0 + S b h \quad (\text{kN})$$

where:

$S$  = distance between the mid-points of two adjacent spans of girders supported by the pillars or the bulkhead stiffeners or bulkhead girders (m) (See **Fig 10.12.1**)

$b$  = mean distance between the mid-points of two adjacent spans of beams supported by the pillars or the frames (m) (See **Fig 10.12.1**)

$h$  = deck load specified in **Ch 10, Sec 2** for the deck supported (kN/m<sup>2</sup>)

$w_0$  = deck load supported by the upper tween deck pillar (kN)

$k$  = as obtained from the following formula according to the ratio of the horizontal distance  $a_i$  (m) from the pillar to the tween deck pillar above to the distance  $l_i$  (m) from the pillar to the pillar or bulkhead (See **Fig 10.12.1**)

$$k = 2 \left( \frac{a_i}{l_j} \right)^3 - 3 \left( \frac{a_i}{l_j} \right)^2 + 1$$

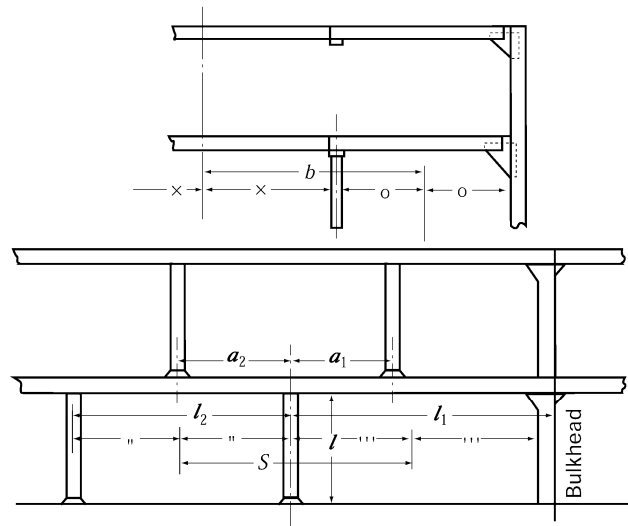

Fig 10.12.1 Measurement of  $S$ ,  $b$ ,  $l$ , etc.

2. Where there are two or more tween deck pillars provided on the deck girder supported by a line of lower pillars, the lower pillar is to be of the scantlings required by **Par 1**, taking  $k w_0$  for each tween deck pillar provided on two adjacent spans supported by the lower pillars.
3. Where tween deck pillars are shifted from the lower pillars in athwartship direction, the scantlings of lower pillars are to be determined in accordance with the principle in **Par 1** and **Par 2**.
4. Where a deck carrying cargoes whose loads can not be treated as evenly distributed loads, deck load supported by pillar is to be determined taking account of load distribution for particular cargoes. Where cargo loads can be treated as concentrated loads acting on specific points, the provisions of **Par 1** and **Par 2** above may be applied so that such concentrated loads are treated as deck loads supported by the upper tween deck pillar ( $w_0$ ).

## 202. Thickness

1. The plate thickness of tubular pillars is not to be less than that obtained from the following formula. This requirement may, however, be suitably modified for the pillars provided in accommodation spaces.

$$t = 0.022d_p + 3.6 \text{ (mm)}$$

where:

$d_p$  = outside diameter of the tubular pillar (mm)

2. The thickness of web and flange plates of built-up pillars is to be sufficient for the prevention of local buckling.

## 203. Outside diameter of round pillars

The outside diameter of solid round pillars and tubular pillars is not to be less than 50 mm.

#### 204. Pillars provided in deep tank

1. Pillars provided in deep tank are not to be tubular pillars.
2. The sectional area of pillars is not to be less than that specified in **201.** or obtained from the following formula, whichever is the greater.

$$a = 1.09 Sbh \text{ (cm}^3\text{)}$$

where:

$S, b$  = as specified in **201.**

$h$  = 0.7 times the vertical distance from the top of deep tank to the point of 2  $m$  above the top of over flow pipe (m)

#### 205. Longitudinal bulkheads and others provided in lieu of pillars

The transverse bulkheads supporting longitudinal deck girders and the longitudinal bulkheads provided in lieu of pillars are to be stiffened in such a manner as to provide supports not less effective than required for pillars.

#### 206. Casings provided in lieu of pillars

The casings provided in lieu of pillars are to be of sufficient scantlings to withstand the deck load and side pressure. ↓

## CHAPTER 13 ARRANGEMENTS TO RESIST PANTING

### Section 1 General

#### 101. Application

1. The requirements in this Chapter are to apply to the bottom and the side constructions in way of both peaks.
2. The side frames are to be in accordance with the requirements in **Ch 8**.

#### 102. Swash plates **[See Guidance]**

In fore and after peaks to be used as deep tanks, effective swash plates are to be provided at the centre line of the ship or the scantlings of structural members are to be suitably increased.

#### 103. Stringers fitted up with extremely small angles **[See Guidance]**

Where the angle between the web of stringers and the shell plating is extremely small, the scantlings of stringers are to be suitably increased above the normal requirements and, where necessary, appropriate supports are to be provided to prevent tripping.

### Section 2 Arrangements to resist Panting Forward the Collision Bulkhead

#### 201. Constructions and arrangements **[See Guidance]**

1. In the place forward the collision bulkhead, the deep centre girder or the longitudinal bulkhead at the centre line is to be provided.
2. In ships with transverse framing, the floor is to be arranged in every frame with sufficient depth and they are to be supported by the side girders provided at an interval of about 2.5 m and below. Frames are to be supported by the constructions specified in **Par 5 to Par 7 of 202**, with the spacing of about 2.5 m.
3. In ships with longitudinal framing, bottom and side longitudinals are to be supported by bottom and side transverse girders having an interval of about 2.5 m. Bottom and side transverse girders are to be supported by side girders and side stringers, or cross tie provided at an interval of about 4.6 m, respectively. And side transverse girders are to be effectively connected with bottom transverse girders.

#### 202. Transverse framing

1. The thickness of floors and centre girders is not to be less than that obtained from the following formula:

$$t = 0.045L + 4.5 \text{ (mm)}$$

2. The floors are to be of adequate depth and to be properly stiffened with stiffeners as may be required.
3. The upper edges of the floors and centre girders are to be properly stiffened.
4. The thickness of side girders is to be approximately equal to that of centre girders and side girders are to extend to such a proper height as may be required according to the height of floors.
5. Where the panting beams are provided at every frame together with perforated steel plates fitted up thereon from side to side, the scantlings of panting beams and steel plates are not to be less than that obtained from the following formulae:

Sectional area of panting beams :  $A = 0.1L + 5$  (cm<sup>2</sup>)

Thickness of steel plates :  $t = 0.02L + 4.5$  (mm)

6. Where the side stringers are provided, their scantlings are not to be less than those obtained from the following formulae:

Depth :  $d_1 = 200l$  (mm),  $d_2 = 5.3L + 250$  (mm) or 2.5 times the depth of slot for the transverse frames (mm), whichever is the greatest

Section modulus :  $Z = 8Shl^2$  (cm<sup>3</sup>)

Thickness of web :  $t = 0.02L + 5.5$  (mm)

where:

$S$  = breadth of area supported by the side stringer (m)

$h$  = vertical distance from the centre of  $S$  to a point of  $0.12L$  (m) above the top of keel (m), but in no case is it to be less than  $0.06L$  (m)

$l$  = distance between the supports of side stringers (m)

7. Where panting beams are provided on alternate frames and stringer plates which are connected to the shell plating are provided at each tier of panting beams, the scantling of panting beams and stringer plates are to comply with the following requirements.

Sectional area of panting beam :  $A = 0.3L$  (cm<sup>2</sup>)

Scantlings of stringer plates :

Breadth :  $b = 5.3L + 250$  (mm)

Thickness :  $t = 0.02L + 5.5$  (mm)

### 203. Longitudinal framing

1. Where the bottom transverses are supported along the centre line, their scantlings are not to be less than those obtained from the following formulae:

Web depth :  $d_1 = 200l$  (mm) or  $d_2 = 8.5L + 180$  (mm), whichever is the greater.

Section modulus :  $Z = 1.2SLl^2$  (cm<sup>3</sup>)

Web thickness :  $t_1 = 5 \frac{SLl}{d_0} + 1.5$  (mm),  $t_2 = 0.6\sqrt{L} + 3$  (mm)

whichever is the greater.

where:

$S$  = spacing of transverses (m)

$l$  = length of transverses between the supporting points (m)

$d_0$  = depth of transverses subtracted by the depth of slot for longitudinals (mm)

2. The scantlings of centre girders are not to be less than those of bottom transverses specified in **Par 1**.
3. The scantlings of side transverses supporting longitudinals are not to be less than those obtained from the following formulae

Web depth :  $d_1 = 200l_0$  (mm),  $5.3L + 250$  (mm) or 2.5 times the depth of slots for longitudinals (mm), whichever is the greatest

Section modulus :  $Z = 8Shl_0^2$  (cm<sup>3</sup>)

Thickness of web :  $t_1 = 42 \frac{Shl_0}{d_0} + 1.5$  (mm),  $t_2 = 0.02L + 5.5$  (mm)

whichever is the greater

where:

$S$  = spacing of transverses (m)

$d_0$  = as specified in **Par 1**

$h$  = vertical distance from the centre of  $l_0$  to a point of  $0.12L$  (m) above the top of keel (m),  
but in no case is it to be less than  $0.06L$  (m)

$l_0$  = length of side transverses between the supporting points (m)

4. Side transverses are to be provided with tripping brackets at an interval of about 3 m and with stiffeners on webs at every longitudinals.
5. The scantlings of side stringers which support side transverses are not to be less than those obtained from the following formulae:

Web depth :  $d_1 = 200l_1$  (mm) or  $d_2 = 5.3L + 250$  (mm), whichever is the greater

Section modulus :  $Z = 4Shl_0l_1$  (cm<sup>3</sup>)

Thickness of web:

$$t_1 = 31 \frac{Shl_1}{d_0} + 1.5 \text{ (mm)}$$

$$t_2 = 0.02L + 5.5 \text{ (mm)}$$

whichever is the greater.

where:

$S$  = breadth of area supported by the stringer (m)

$h$  = vertical distance from the centre of  $S$  to a point of  $0.12L$  (m) above the top of keel (m),  
but in no case is it to be less than  $0.06L$  (m)

$l_0$  = as stipulated in **Par 3**

$l_1$  = length of side stringers (m)

$d_0$  = as stipulated in **Par 1**

6. The sectional area of cross ties supporting the transverses is not to be less than that obtained from the following formulae:

Where  $l/k$  is 0.6 and above :  $A = \frac{0.77Sbh}{1 - 0.5 \frac{l}{k}}$  (cm<sup>2</sup>)

Where  $l/k$  is less than 0.6 :  $A = 1.1Sbh$  (cm<sup>2</sup>)

where:

$S$  = spacing of transverses (m)

$b$  = breadth of area supported by the cross ties (m)

$h$  = vertical distance from the centre of  $b$  to a point of  $0.12L$  (m) above the top of keel (m),  
but in no case is it to be less than  $0.06L$  (m)

$l$  = length of cross ties (m)

$k$  = minimum radius of gyration of cross ties, obtained from the following formula (cm)

$$k = \sqrt{\frac{I}{A}}$$

$I$  = the least moment of inertia of the cross ties (cm<sup>4</sup>)

$A$  = sectional area of the cross ties (cm<sup>2</sup>)

- (1) Cross ties are to be effectively connected to the transverses by brackets or other suitable arrangements and the transverses are to be provided with tripping brackets in way of the cross ties.
- (2) Where the breadth of face plate of cross ties on either side of the web exceeds 150 mm, stiffeners are to be provided on the webs and so arranged as to support the face plate at a suitable interval.

### Section 3 Arrangements to resist Panting Aft Aft Peak Bulkhead

#### 301. Floors

The scantlings and arrangements of floors in after peak are to be in accordance with the requirements in **202**.

#### 302. Frames

Where the length of girth between the supporting points of frames exceeds 2.5 m, the scantlings of frames are to be increased or suitably strengthened to give adequate stiffness to the structure.

#### 303. Other construction members

Where the constructions in after peak are in compliance with the requirements for fore peak in **Sec 2**, the scantlings of transverses, stringers and struts may be 0.67 times the values specified in **Sec 2**. ↓

## CHAPTER 14 WATERTIGHT BULKHEADS

### Section 1 Arrangement

#### 101. Collision bulkheads **【See Guidance】**

- All ships except where the larger distance is accepted by the Society due to special structural reasons are to have a collision bulkhead at the position between  $0.05 L_f$  and  $0.05 L_f + 3$  m, but at position between  $0.05 L_f$  and  $0.13 L_f$  for the ships are engaged in great coastal services and whose tonnages are less than 500 ton, the ships are engaged in under coastal services and fishing vessels, measured from the forward end of the length for freeboard. However, where any part of the ship below the waterline at 85% of the least moulded depth extends forward beyond the forward terminal of the length for freeboard, the above-mentioned distance is to be measured from following points whichever gives the smaller measurement:
  - at the mid-length of such extension; or
  - at a point of  $0.015 L_f$  forward from the abovementioned forward end.
- The bulkhead may have steps or recesses within the limits specified in the above **Par 1**.
- Arrangement of collision bulkhead in a ship provided with bow door is to be at the discretion of the Society. However, where a sloping ramp forms a part of the collision bulkhead above the freeboard deck, the part of the ramp which is more than 2.3 m above the freeboard deck may extend forward of the limit specified in the above **Par 1**. In this case, the ramp is to be weathertight over its complete length.

#### 102. After peak bulkheads

- All ships are to have an after peak bulkhead situated at a suitable position.
- The stern tube is to be enclosed in a watertight compartment by the after peak bulkhead or other suitable arrangements.

#### 103. Machinery space bulkheads

- A watertight bulkhead is to be provided at each end of the machinery space.
- Where the machinery space is arranged in aft end of ship, the after side bulkhead of machinery space among the bulkheads in **Par 1** may be regarded as an aft peak bulkhead of ship.

#### 104. Hold bulkheads **【See Guidance】**

- Cargo ships, of the ordinary type and of 67 m or above in length are to have hold bulkheads in addition to the bulkheads specified in **101.** to **103.** at a reasonable interval so that the total number of the watertight bulkheads may not be less than that given by **Table 10.14.1**.

**Table 10.14.1** Number of watertight bulkheads

Length of ships (m)	Total number of bulkheads	
	Ships with machinery space at aft end of ship	Ships with machinery space other than at aft end of ship
$67 \leq L < 87$	4	4
$87 \leq L < 90$	4	5

- The arrangement of bulkheads may not apply the requirement in **Par 1** subject to the approval by the Society.

### 105. Height of watertight bulkheads

The watertight bulkheads required in **101.** to **104.** are to extend to the freeboard deck with the following exceptions:

- (1) A watertight bulkheads in way of the raised quarter or the sunken forecastle deck is to extend up to the said deck.
- (2) Where a forecastle having opening without closing appliances led to a space below the freeboard deck, or a long forecastle is provided, the collision bulkhead is to extend to the superstructure deck and to be made weathertight. However, where the extension is located within the limits specified in **101.** and the part of the deck which forms the step is made effectively weathertight, it need not be fitted directly above the bulkhead thereunder.
- (3) The aft peak bulkhead may terminate at a deck below the freeboard deck and above the load line, provided that this deck is made watertight to the stern of the ship.

### 106. Construction

1. Where the watertight bulkheads required in **101.** to **105.** are not extended up to the strength deck, deep webs or partial bulkheads situated immediately or nearly above the main watertight bulkheads are to be provided so as to maintain the transverse strength and stiffness of the hull.
2. Where the length of a hold exceeds 30 m, suitable means are to be provided so as to maintain the transverse strength and stiffness of the hull.

### 107. Chain lockers **[See Guidance]**

1. Spurling pipes and cable lockers are to be watertight up to the weather deck. Bulkheads between separate cable lockers, or which form a common boundary of cable lockers need not however be watertight.
2. Where means of access is provided, it is to be closed by a substantial cover and secured by closely spaced bolts.
3. Where a means of access to spurling pipes or cable lockers is located below the weather deck, the access cover and its securing arrangements are to be in accordance with recognized standards(e.g. ISO 5894 etc.) or equivalent for watertight manhole covers. Butterfly nuts and/or hinged bolts are prohibited as the securing mechanism for the access cover.
4. Spurling pipes through which anchor cables are led are to be provided with permanently attached closing appliances to minimize water ingress.

## Section 2 Construction

### 201. Thickness

The thickness of bulkhead plating is not to be less than that obtained from the following formula:

$$t = 3.2S\sqrt{h} + 1.5 \text{ (mm)}$$

where:

$S$  = spacing of stiffeners (m)

$h$  = vertical distance from the lower edge of plate to the bulkhead deck at centre (m), but in no case is it to be less than 3.4 m

### 202. Increase of thickness

1. The thickness of lowest strake of plating is not to be less than obtained from the above formula given in **201.** plus 1 mm.
2. The lowest strake of bulkhead plating is to extend at least 610 mm above the top of inner bottom

plating in way of double bottom or 915 mm above the top of keel in way of single bottom. Where the double bottom is provided only on one side of the bulkhead, the extension of the lowest strake is to be of the greater value among the two cases above.

3. The bulkhead platings in way of bilge wells are to be at least 2.5 mm thicker than given by **201**.
4. The bulkhead plating is to be doubled or increased in thickness in way of stern tube opening, notwithstanding the requirements in **201**.

### 203. Stiffeners **【See Guidance】**

The section modulus of bulkhead stiffeners is not to be less than that obtained from the following formula:

$$Z = CS hl^2 \text{ (cm}^3\text{)}$$

where :

$l$  = span measured between the adjacent supports of stiffeners including the length of connection (m). Where girders are provided, it is the distance from the heel of end connection to the first girder or the distance between the girders.

$S$  = spacing of stiffeners (m)

$h$  = vertical distance measured from the midpoint of  $l$  for vertical stiffeners, and from the midpoint of distance between the adjacent stiffeners for horizontal stiffeners, to the top of bulkhead deck at the centre line of ship (m). Where the vertical distance is less than 6.0 m,  $h$  is to be taken as 1.2 m greater than 0.8 times the vertical distance.

$C$  = coefficient given in **Table 10.14.2** according to the type of end connection.

Table 10.14.2 Value of *C*

	Lower end \ Upper end	Lug-connection of supported by horizontal girders	Connection		End of stiffener unattached
			Type A	Type B	
Vertical Stiffener	Lug-connection or supported by horizontal girders	2.80	2.80	3.22	3.78
	Bracketed	2.24	2.24	2.52	2.80
	Only the web of stiffener attached at end	3.22	3.22	3.78	4.48
	End of stiffener unattached	3.78	3.78	4.48	5.60
Horizontal Stiffener	One end \ The other end	Lug-connection, bracketed or supported by vertical girders		End of stiffener unattached	
	Lug-connection bracketed or supported by vertical girders	2.80		3.78	
	End of stiffener unattached	3.78		5.60	

(NOTES)

- "Lug-connection" is such a connection as both web and face bar of stiffener are effectively attached to the bulkhead plating, decks or inner bottoms which are strengthened by effective supporting members on the opposite side of plating.
- "Connection-Type A" of vertical stiffeners is a connection by bracket to the longitudinal members or to the adjacent members, in line with the stiffeners, of the same or larger sections. (See Fig 10.14.1 (a))
- "Connection-Type B" of vertical stiffeners is a connection by bracket to the transverse members such as beams, or other connections equivalent to the connections mentioned above. (See Fig 10.14.1 (b))

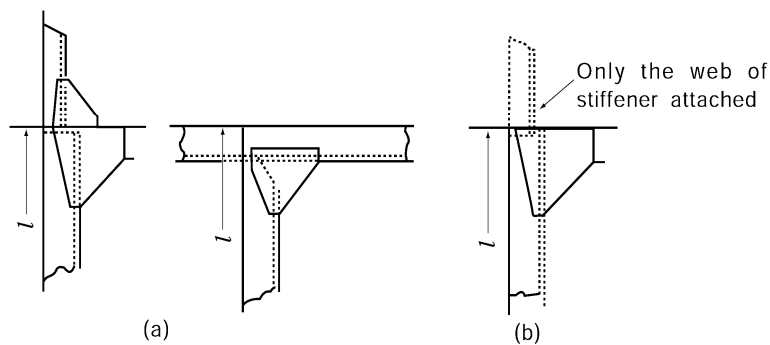

Fig 10.14.1 Types of end connection

**204. Collision bulkheads**

For collision bulkheads, the plate thickness and section modulus of stiffeners are not to be less than those specified in 201. and 203. taking *h* as 1.25 times the specified height.

**205. Girders**

- The section modulus of girders supporting bulkhead stiffeners (hereinafter referred to as girder) is not to be less than that obtained from the following formula:

$$Z = 4.75 S h l^2 \text{ (cm}^3\text{)}$$

where:

$S$  = breadth of the area supported by the girder (m)

$h$  = vertical distance measured from the midpoint of  $l$  for vertical girders, and from the mid-point of  $S$  for horizontal girders, to the top of bulkhead deck at the centre line of ship (m). Where the vertical distance is less than 6.0 m,  $h$  is to be taken as 1.2 m greater than 0.8 times the vertical distance.

$l$  = span measured between the adjacent supports of girders (m)

2. The moment of inertia of girders is not to be less than obtained from the following formula. In no case is the depth of girders to be less than 2.5 times the depth of slots for stiffeners.

$$I = 10hl^4 \text{ (cm}^4\text{)}$$

where:

$h, l$  = as specified in **Par 1**

3. The thickness of web plates is not to be less than that obtained from the following formula;

$$t = 0.01S_1 + 1.5 \text{ (mm)}$$

where:

$S_1$  = spacing of web stiffeners or depth of girders, whichever is the smaller (mm)

4. Tripping brackets are to be provided at an interval of about 3 m and where the breadth of face plates exceeds 180 mm on either side of the girder, these brackets are to be so arranged as to support the face plates.

### 206. Strengthening of bulkhead plating, deck plating, etc.

Platings of bulkheads, decks, inner bottoms, etc. are to be, if necessary, strengthened at the location of the end brackets of stiffeners and the end of girders.

### 207. Bulkhead recesses

1. In way of bulkhead recesses, beams are to be provided at every frame and under the upper bulkhead in accordance with the requirements in **Ch 10, 403.** and **Ch 14, 203.** taking the beam spacing as the stiffener spacing. Where the lower end of upper bulkhead is specially strengthened, the beam under the upper bulkhead may be dispensed with.
2. The thickness of deck plating in way of bulkhead recesses is to be at least 1 mm greater than that given by **201.**, regarding the deck plating as bulkhead plating and the beams as stiffeners respectively. In no case is the thickness to be less than that required for deck plating in that location.
3. The thickness of pillars supporting bulkhead recesses is to be determined taking account of the water pressure which might be applied on the upper surface of recesses, and their end connections are to be sufficient to withstand the water pressure which might be applied on the under surface.

### 208. Construction of bulkheads in way of watertight doors

Where stiffeners are cut or the spacing of stiffeners is increased in order to provide the watertight door in the bulkhead, the opening is to be suitably framed and strengthened as to maintain the full strength of the bulkhead. In no case are the door frames to be considered as stiffeners.

---

---

## Section 3 Watertight Doors (2020)

### 301. General

1. As specified in Pt 3, Ch 14, 401. of the Rules.

### 302. Type of watertight doors **【See Guidance】**

1. As specified in Pt 3, Ch 14, 402. of the Rules.

### 303. Strength and watertightness **【See Guidance】**

1. As specified in Pt 3, Ch 14, 403. of the Rules.

### 304. Control **【See Guidance】**

1. As specified in Pt 3, Ch 14, 404. of the Rules.

### 305. Indication **【See Guidance】**

1. As specified in Pt 3, Ch 14, 405. of the Rules.

### 306. Alarms **【See Guidance】**

1. As specified in Pt 3, Ch 14, 406. of the Rules.

### 307. Source of power **【See Guidance】**

1. As specified in Pt 3, Ch 14, 407. of the Rules.

### 308. Notices

1. As specified in Pt 3, Ch 14, 408. of the Rules.

### 309. Sliding doors **【See Guidance】**

1. As specified in Pt 3, Ch 14, 409. of the Rules.

### 310. Hinged and rolling doors

1. As specified in Pt 3, Ch 14, 410. of the Rules.

### 311. Testing **【See Guidance】**

1. As specified in Pt 3, Ch 14, 412. of the Rules. ↴

## CHAPTER 15 DEEP TANKS

### Section 1 General

#### 101. Definition

The deep tank is a tank used for carriage of water, fuel oil and other liquids, forming a part of the hull in holds. The deep tanks used for carriage of oils are designated as “deep oil tanks”, if necessary.

#### 102. Application

1. Peak tank bulkheads and boundary bulkheads of deep tank (excluding the deep tanks for carriage of oils having flashpoint below 60°C) are to be constructed in accordance with the requirements in this Chapter. Where the bulkhead of deep tank partly serves as a watertight bulkhead, the part of the bulkhead is to be in accordance with the requirements in **Ch 14**.
2. The requirements in **Ch 23** and **Ch 24** are to be applied to the bulkheads of the deep tanks for carriage of oils having a flashpoint below 60°C, in addition to those in this Chapter.

#### 103. Divisions in tanks **[See Guidance]**

1. Deep tanks are to be of proper size and to be provided with such longitudinal watertight divisions as necessary to meet the requirements for stability in service conditions as well as while the tanks are being filled or discharged.
2. Tanks for fresh water or fuel oil or those which are not intended to be kept entirely filled in service conditions are to have additional divisions or deep wash plates as necessary to minimize the dynamic forces acting on the structure.
3. Where it is impracticable to comply with the requirements in **Par 2**, the scantlings required in this Chapter are to be properly increased.
4. Longitudinal watertight divisions which will be subjected to pressure from both sides, in tanks which are to be entirely filled or emptied in service conditions, may be of the scantlings required for ordinary watertight bulkheads by **Ch 14**. In such cases, the tanks are to be provided with deep hatches, etc., fitted with inspection plugs in order to ensure that the tanks are kept full in service conditions.

### Section 2 Bulkheads of Deep Tanks

#### 201. Application

The construction of bulkheads and decks forming boundaries of deep tanks is to be in accordance with the requirements in **Ch 14**, unless otherwise specified in this Chapter.

#### 202. Bulkhead plates (2020) **[See Guidance]**

The thickness of deep tank bulkhead plating is not to be less than that obtained from the following formula:

$$t = 3.6S\sqrt{h} + 2.5 \text{ (mm)}$$

where :

$S$  = spacing of stiffeners (m)

$h$  = distance given below, whichever is the greater:

$h_1$  = Vertical distance measured from the lower edge of plate to the midpoint of the distance between the top of tanks and the top of overflow pipes (m). For bulkheads of

large tanks, additional water pressure is to be considered.

$h_3$  = 0.7 times the vertical distance measured from the lower edge of plate to the point of 2.0 m above the top of overflow pipes (m)

When the ship use the flow-through ballast water exchange operations method, the following water heads,  $h_4$  is to be additionally considered.

$h_4$  = Vertical distance from the lower edge of the bulkhead plating under consideration to the top of the overflow pipe (or air pipe) to the point where the overpressure is added (m). (Overpressure : due to sustained liquid flow through overflow pipe in case of overfilling or filling during flow through ballast water exchange. It is to be defined by the designer, but not to be less than 2.5.) For bulkheads of large tanks, additional water pressure is to be considered.

### 203. Bulkhead stiffeners (2020) [See Guidance]

The section modulus of bulkhead stiffeners is not to be less than that obtained from the following formula:

$$Z = CShl^2 \text{ (cm}^3\text{)}$$

where:

$S, l$  = as specified in **Ch 14, 203**.

$h$  = water head  $h_1$  or  $h_3$  as specified in **202.**, whichever is the greater, the lower end being regarded as the midpoint of  $l$  for vertical stiffeners and as the midpoint of distance between the adjacent stiffeners for horizontal stiffeners. When the ship use the flow-through ballast water exchange operations method,  $h_4$  as specified in **202.** are to be additionally considered.

$C$  = coefficient given in **Table 10.15.1** according to the type of end connections

**Table 10.15.1 Value of  $C$**

One end of stiffeners \ The other end of stiffeners	Connection by hard bracket	Connection by soft bracket	Supported by girders or lug connection	Snip
Connection by hard bracket	4.90	8.05	5.95	9.10
Connection by soft bracket	8.05	5.95	9.10	8.05
Supported by girders or lug connection	5.95	9.10	7.00	10.50
Snip	9.10	8.05	10.50	10.50

(NOTES)

1. Connection by hard bracket is a connection by bracket to the double bottoms or to the adjacent members, such as longitudinals or stiffeners in line, of the same or larger sections, or a connection by bracket to the equivalent members mentioned above. (See Fig 10.14.1 (a)).
2. Connection by soft brackets is a connection by bracket to the transverse members such as beams or equivalent thereto. (See Fig 10.14.1 (b)).

### 204. Girders supporting bulkhead stiffeners [See Guidance]

1. The section modulus of girders supporting bulkhead stiffeners (hereinafter referred to as girder) is not to be less than that obtained from the following formula:

$$Z = 7.13Shl^2 \text{ (cm}^3\text{)}$$

where:

$S$  = breadth of the area supported by the girders (m)

$h$  = vertical distance measured from the midpoint of  $S$  for horizontal girders, and from the mid-point of  $l$  for vertical girders, to the top of  $h$  specified in **203**. (m)

$l$  = span specified in **Ch 14, 203**. (m)

- The moment of inertia of girders is not to be less than that obtained from the following formula. In no case is the depth of girders to be less than 2.5 times the depth of slots for stiffeners.

$$I = 30hl^4 \quad (\text{cm}^4)$$

where:

$h, l$  = as specified in **Par 1**

- The thickness of plates of web parts is not to be less than that obtained from the following formula:

$$t = 0.01S_1 + 2.5 \quad (\text{mm})$$

where:

$S_1$  = spacing of web stiffeners or the depth of girders, whichever is the smaller (mm)

### 205. Cross ties

- Where efficient cross ties are provided across deep tanks connecting girders on each side of the tanks, the span of girders specified in **204**. may be measured between the end of girder and the centre line of cross tie or between the centre lines of adjacent cross ties.
- The sectional area of cross ties is not to be less than that obtained from the following formula:

$$A = 1.3Sb_s h \quad (\text{cm}^2)$$

where:

$S, h$  = as specified in **204**.

$b_s$  = breadth of the area supported by the cross ties (m)

- The ends of cross ties are to be bracketed to girders.

### 206. Top and bottom construction

The scantlings of the members forming the top or the bottom of deep tanks are to be in accordance with the requirements in this Chapter, regarding the members as the members forming the deep tank bulkheads at the location. In no case are they to be less than required for the deck plating or the bottom plating at the location. For top plating of deep tanks the thickness of plates is to be at least 1 mm greater than the thickness specified in **202**.

### 207. Scantling of members not in contact with sea water

The thickness of plates of bulkheads and girders which are not in contact with sea water in service conditions may be reduced from the requirements in **202**. and **204**. by the values given below:

For the plates of which only one side is in contact with sea water ..... 0.5 mm

For the plates of which neither side is in contact with sea water ..... 1.0 mm

However, bulkhead plates in way of the location such as bilge wells are to be regarded as the plates in contact with sea water.

### 208. Corrugated bulkheads (2016)

Construction of corrugated bulkheads is to be in accordance with the requirements given in Pt 3, Ch 15, 207. of the Rules.

## Section 3 Fittings of Deep Tanks

### 301. Limbers and air holes

Limbers and air holes are to be cut suitably in the structural members to ensure that air or water does not remain stagnated in any part of the tank.

### 302. Drainage

Efficient arrangement is to be made for draining bilge water on the top of deep tanks.

### 303. Inspection plugs

The inspection plugs provided on deep tank tops as required in 103. 4 are to be located in readily accessible positions, and the filling of water is to be done leaving the plugs open as far as possible.

### 304. Cofferdams

1. As specified in Ch 7, 104. (2026)
2. Crew spaces and passenger spaces are not to be directly adjacent to the tanks for carriage of fuel oil. Such compartments are to be separated from the fuel oil tanks by cofferdams which are well ventilated and are not less than 600 mm in width for easy access. Where the top of fuel oil tanks has no opening and is coated with incombustible coverings of 38 mm and over in thickness, the cofferdam between such compartments and the top of fuel oil tanks may be omitted.

## Section 4 Welding of Corrugated Bulkheads (2016)

### 401. General

Welding of corrugated bulkheads is to be in accordance with the requirements given in Pt 3, Ch 15, Sec. 4 of the Rules. ↓

## CHAPTER 16 SUPERSTRUCTURES AND DECKHOUSES

### Section 1 General

#### 101. Application

1. All ships are to have forecastles except any of following ships and where an adequate bow freeboard is deemed sufficient by the Society.
  - (1) the ships with satisfaction of requirements of bow height for calculation of summer freeboard
  - (2) any of following oil tankers engaged in domestic voyage and less than 60 m in length
    - (A) the ships engaged in smooth water service
    - (B) the ships which are navigate to be less than 2 hour with their maximum speed in area over smooth water area
    - (C) the ship of which the vertical distance at F.P measured from designed load line to top of the superstructure deck at side is 0.05 L or greater
  - (3) any of following ships other than oil tankers
    - (A) the ships engaged in under costal service (excluding international voyage)
    - (B) the ships engaged in great coastal service (excluding international voyage) and less than 60 m in length
2. The construction and scantlings of superstructures and deckhouses are to be in accordance with the requirements in the relevant Chapters in addition to this Chapter.
3. The requirements in this Chapter are prescribed for the superstructures and deckhouses up to the third tier above the freeboard deck. As for the superstructures and deckhouses above the third tier, the construction and scantlings thereof are to be as deemed appropriate by the Society. **[See Guidance]**
4. As for the superstructures and deckhouses in ships with specially large freeboard, the construction of bulkhead may be suitably modified subject to the approval by the Society.

### Section 2 Construction

#### 201. Head of water

1. The head of water for the calculation of the scantlings of superstructure end bulkheads and boundary wall of deckhouses is not to be less than that obtained from the following formula:

$$h = ac(0.067bL - y) \text{ (m)}$$

where:

$a$  = as given in **Table 10.16.1**

$b$  = as given in **Table 10.16.2**

$c$  = as given in **Table 10.16.3**

$y$  = vertical distance from the summer waterline to the mid-point of span of stiffener in case where the scantlings of stiffeners are determined, and to the mid-point of plate in case where the thickness of bulkhead plating is determined (m)

2. The head of water for the calculation of the scantlings of superstructure end bulkheads and boundary walls of deckhouses is not to be less than obtained from the formulae in **Table 10.16.4**, irrespective of the provisions in **Par 1**.

**Table 10.16.1 Values of *a***

Bulkhead and wall	Location	<i>a</i>
Exposed front bulkhead and wall	First tier	$\frac{L}{120} + 2.0$
	Second tier	$\frac{L}{120} + 1.0$
	Third tier	$\frac{L}{150} + 0.5$
Side Walls and protected end bulkheads and front walls of the all tier		
Aft bulkhead and wall	Afterward of the midship	$\frac{L}{1000} - 0.8 \frac{x}{L} + 0.7$
	Forward of the midship	$\frac{L}{1000} - 0.4 \frac{x}{L} + 0.5$

*L* = length of ship (m)  
*x* = distance from the bulkhead or end wall to the after perpendicular, or distance from the mid-point of side wall to the after perpendicular (m). Where, however, the length of side wall exceeds 0.15 *L*, the side wall is to be nearly equally subdivided as not to exceed 0.15 *L* and the distance from the mid-point of the subdivision to the after perpendicular is to be taken.

**Table 10.16.2 Values of *b***

$\frac{x}{L}$	<i>b</i>
$\frac{x}{L} < 0.45$	$\left(0.5 - 1.1 \frac{x}{L}\right)^2 + 1.0$
$\frac{x}{L} \geq 0.45$	$1.5 \left(1.1 \frac{x}{L} - 0.5\right)^2 + 1.0$

*L, x* = as specified in Table 10.16.1

**Table 10.16.3 Values of *c***

Locations	<i>c</i>
End bulkheads of superstructures	1.0
Boundary walls of deckhouses	$0.7 \frac{b'}{B'} + 0.3$ However, $\frac{b'}{B'}$ is less than 0.25, <i>b'/B'</i> is to be taken as 0.25

*b'* = breadth of deckhouse at the position under consideration (m)  
*B'* = breadth of ship on the exposed deck at the position under consideration (m)

**Table 10.16.4 Head of water, *h* (m)**

Length of ship (m)	Exposed front bulkhead of the 1st tier superstructure	Others
$L \leq 50$	3.0	1.5
$50 < L < 90$	$\frac{L}{100} + 2.5$	$\frac{L}{200} + 1.25$

## 202. Thickness of bulkhead and wall platings

1. The thickness of superstructure end bulkhead plating and side wall plating is not to be less than that obtained from the following formula or minimum thickness, whichever is the greater, in **Par 2** and **Par 3**.

$$t = 3S\sqrt{h} \text{ (mm)}$$

where:

$h$  = head of water specified in **201**. (m)

$S$  = spacing of stiffeners (m)

2. For ships not less than 65 m in length, the minimum thickness of the bulkhead obtained from the following formula.

$$t_{\min} = \frac{L}{100} + 5.0 \text{ (mm) for lowest tier}$$

$$t_{\min} = 5.0 \text{ (mm) for upper tiers}$$

3. For ships less than 65 m in length, the minimum thickness of the bulkhead obtained from the following formula.

$$t_{\min} = 5.0 \text{ (mm) for the lowest unprotected tier}$$

$$t_{\min} = 4.0 \text{ (mm) for all other cases}$$

## 203. Stiffeners

1. The section modulus of stiffeners on superstructure end bulkheads and deckhouse boundary walls is not to be less than that obtained from the following formula:

$$Z = 3.5Shl^2 \text{ (cm}^3\text{)}$$

where:

$S$ ,  $h$  = as specified in **202**.

$l$  = tween deck height (m). Where, however,  $l$  is less than 2 m,  $l$  is to be taken as 2 m.

2. Both ends of stiffeners on the exposed bulkheads of superstructures and boundary walls of deckhouses are to be connected to the deck by welding except where otherwise approved by the Society.

## Section 3 Access Openings in Superstructure End Bulkheads

### 301. Closures for access openings **[See Guidance]**

1. The doors to be provided on the access openings in the end bulkheads of enclosed superstructures and deckhouses protecting companion ways giving access to the spaces under the freeboard deck or the spaces in the enclosed superstructures are to be in accordance with the requirements in (1) through (5) :

(1) The doors are to be made of steel or other equivalent materials and to be permanently and rigidly fitted up to the bulkheads.

- (2) The doors are to be rigidly constructed, to be of equivalent strength to that of intact bulkhead and to be weathertight when closed.
- (3) The means for securing weathertightness are to consist of gaskets and clamping devices or other equivalent devices and to be permanently fitted up to the bulkhead or the door itself.
- (4) The doors are to be operated from the both sides of the bulkheads.
- (5) Hinged doors are, as a rule, to open outward.

2.

- (1) The height of sills of access openings specified in **Par 1** is not to be less than 380 mm above the upper surface of the deck except where higher sills may be required when deemed necessary by the Society.
- (2) In principle, portable sills are not permitted.

3. Openings in the top of a deckhouse on a raised quarterdeck or superstructure of less than standard height, having a height equal to or greater than the standard quarterdeck height, are to be provided with an acceptable means of closing but need not be protected by an efficient deckhouse or companionway, provided that the height of the deckhouse is at least the standard height of a superstructure. Openings in the top of the deckhouse on a deckhouse of less than a standard superstructure height may be treated in a similar manner. ↓

## CHAPTER 17 MACHINERY SPACES AND ENGINE CASINGS

### Section 1 General

#### 101. Application

The construction of machinery space in addition to this Chapter is to be in accordance with the requirements in relevant Chapters.

#### 102. Compensation **【See Guidance】**

Machinery space is to be sufficiently strengthened by means of web frames, strong beams and pillars or other suitable arrangements.

#### 103. Construction

Machineries, shafting, etc are to be efficiently supported and the adjacent structures are to be adequately stiffened.

#### 104. Twin screw ships and others of high power

In twin screw ships and others of high power, the structure and attachments of the seatings are to be specially strengthened in relation to the proportion of the height of engines to their length or width, weight, power, type, etc.

### Section 2 Main Engine Foundations

#### 201. Ships with single bottoms

1. In ships with single bottoms, the main engines are to be seated upon thick rider plates laid across the top of deep floors or heavy foundation girders efficiently bracketed and stiffened and having sufficient strength in proportion to the power and size of engines.
2. Girder plates are to be provided beneath the main lines of bolting of main engines and the holding down bolts are to pass through the rider plates on the girder plates.
3. In ships having the engine on the centre line of hull, where the longitudinal girders are to be provided under the engine and their spacing is not very wide, the centre girder may be omitted. **【See Guidance】**

#### 202. Ships with double bottoms **【See Guidance】**

1. In ships with double bottoms, the main engine is to be seated directly upon thick inner bottom plating or thick seat plates on the top of heavy foundations so arranged as to effectively distribute the weight.
2. Additional side girders are to be provided within the double bottom beneath the main lines of bolting and other suitable positions so as to ensure satisfactory distribution of the weight and rigidity of the structure.

### Section 3 Construction of Boiler Rooms

#### 301. Boiler foundations

1. Boilers are to be supported by deep saddle type floors or by transverse or longitudinal girders so arranged as to effectively distribute the weight.
2. Where boilers are supported by transverse saddles or girders, the floors in way of same are to be

specially stiffened.

### 302. Boiler location

1. Boilers are to be so placed as to ensure accessibility and proper ventilation.
2. Boilers are to be at least 457 mm clear of tank tops, etc. The thickness of adjacent members is to be increased as may be required where the clear space is unavoidably less. The available clearance is to be indicated on the plans submitted for approval.
3. Hold bulkheads and decks are to be kept well clear of the boilers and uptakes, or provided with suitable insulating arrangements.
4. Side sparrings are to be provided on the bulkheads adjacent to the boilers, keeping suitable clearance on their hold sides.

## Section 4 Thrust Blocks and Foundations

### 401. Thrust blocks and foundations

1. Thrust blocks are to be bolted to efficient foundations extending well beyond the thrust blocks and so arranged as to effectively distribute the loads into the adjacent structures.
2. Additional girders are to be provided in way of the foundations as necessary.

### 402. Plummer blocks and auxiliary machinery seats

Plummer blocks and auxiliary machinery seats are to be of ample strength and stiffness in proportion to the weight supported and to the height of foundations.

## Section 5 Machinery Space Openings

### 501. Protection of machinery space openings

Machinery space openings are to be enclosed by steel casings.

### 502. Exposed machinery space casings

1. Exposed machinery space casings are to have scantlings not less than those required in **Ch 16, 201.** and **202.**, taking  $c$  value as 1.0.
2. The thickness of top plating of exposed machinery space casing is not to be less than that obtained from the formulae given in **Table 10.17.1.**

**Table 10.17.1 Thickness of top plating of exposed casing**

Position	Thickness (mm)
I	$t = 6.3S + 1.5$
II	$t = 6.0S + 1.5$
$S =$ spacing of stiffeners (m)	

### 503. Machinery space casings below freeboard deck or within enclosed spaces

The scantlings of machinery space casings below the freeboard deck or within enclosed superstructures or deckhouses are to comply with the following requirements:

- (1) The thickness of plating is to be at least 6.5 mm, where the spacing of stiffeners is greater than 760 mm, the thickness is to be increased at the rate of 0.5 mm per 100 mm excess in spacing.

In accommodation spaces the thickness of plating may be reduced by 2 mm.

- (2) The section modulus of stiffeners is not to be less than that obtained from the following formula:

$$Z = 1.2 S l^3 \text{ (cm}^3\text{)}$$

where:

$l$  = tween deck height (m)

$S$  = spacing of stiffeners (m)

#### 504. Access openings to machinery spaces

1. All access openings to machinery spaces are to be located in protected positions as far as possible and provided with steel doors capable of being closed and secured from both sides. Such doors in exposed machinery space casings on the freeboard deck are to comply with the requirements in **Ch 16, 301. 1.**
2. The sills of doorways in machinery space casings are not to be less than 600 mm in height above the upper surface of the deck in Position I and 380 mm in Position II.
3. In ships having a reduced freeboard, doorways in the exposed machinery space casings on the freeboard or raised quarter deck are to lead to a space or passageway which is of strength equivalent to that of the casing and is separated from the stairway to the machinery spaces by a second steel weathertight door of which the doorway sill is to be at least 230 mm in height.

#### 505. Miscellaneous openings in machinery space casing

1. Coamings of any fiddle, funnel and machinery space ventilator in an exposed position on the freeboard or superstructure deck are to be as high above the deck as reasonable and practicable.
2. In exposed positions on the freeboard and superstructure decks, fiddle openings and all other openings in the machinery space casings are to be provided with strong steel weathertight covers permanently fitted up in their proper positions.
3. Annular spaces around funnels and all other openings in the machinery space casings are to be provided with closing means capable of being operated from outside the machinery space in case of a fire.

#### 506. Machinery space casings within unenclosed superstructure or deckhouses

Machinery space casings within unenclosed superstructures or deckhouses and doors provided thereon are to be constructed to the satisfaction of the Society, having regard to the degree or protection afforded by the superstructure or deckhouse. ↓

---

## CHAPTER 18 TUNNELS AND TUNNEL RECESSES

### Section 1 General

As specified in Pt 3, Ch 19, Sec 1 ↓

---

## CHAPTER 19 HATCHWAYS AND OTHER DECK OPENINGS

### Section 1 General

#### 101. Application

Hatchways and other deck openings are to comply with Pt 4, Ch 2.

#### 102. Openings to cargo spaces

Access and other openings to cargo spaces are to be provided with closing means capable of being operated from outside the spaces in case of a fire. Such closing means for any opening leading to any other space inboard the ship is to be of steel. ⚴

---

## CHAPTER 20 BOW DOORS, SIDE AND STERN DOORS

### Section 1 Bow doors and Inner Doors

As specified in Pt 4, Ch 3, Sec 1

### Section 2 Side and Stern Door

As specified in Pt 4, Ch 3, Sec 2 ↓

---

## CHAPTER 21 BULWARKS FREEING PORTS, SIDE SCUTTLES, VENTILATORS AND PERMANENT GANGWAYS

### Section 1 Bulwarks

As specified in Pt 4, Ch 4, Sec 1

### Section 2 Freeing Ports 【See Guidance】

As specified in Pt 4, Ch 4, Sec 2

### Section 3 Side Scuttles 【See Guidance】

As specified in Pt 4, Ch 4, Sec 3

### Section 4 Ventilators

As specified in Pt 4, Ch 4, Sec 4

### Section 5 Permanent Gangways

As specified in Pt 4, Ch 4, Sec 5 ↓

---

---

## CHAPTER 22 EQUIPMENT NUMBER AND EQUIPMENT

### Section 1 General

#### 101. General and application (2020) [See Guidance]

1. Equipment number and Equipment are to be in accordance with the **Pt 4, Ch 8** of the rules.
2. The provision of anchors, chain cables, ropes, etc. having constructions of special shape and dimensions is to be in accordance with the discretion of the Society.

### Section 2 Equipment Number (2020)

#### 201. Equipment number

As specified in **Pt 4, Ch 8, Sec 2** of the rules.

#### 202. Mass of anchors

As specified in **Pt 4, Ch 8, Sec 2** of the rules.

#### 203. Chain cables and stream lines

As specified in **Pt 4, Ch 8, Sec 2** of the rules.

#### 204. Tow lines and mooring lines

As specified in **Pt 4, Ch 8, Sec 2** of the rules.

### Section 3 Shipboard Fittings and Supporting Hull Structures associated with Towing and Mooring

#### 301. Shipboard fittings and supporting hull structures

Shipboard fittings and supporting hull structures associated with towing and mooring, where applicable, are to comply with the requirements specified in **Pt 4, Ch 10**. (2020) ↕

## CHAPTER 23 OIL TANKERS

### Section 1 General

#### 101. Application

1. The construction and equipment of ships intended to be registered and classed as "tanker" are to be in accordance with the requirements in this Chapter, where "tanker" means a ship intended to carry crude oil, petroleum products having the vapour pressure (absolute pressure) less than 0.28 MPa at 37.8°C or other similar liquid cargoes in bulk.
2. Except where specifically required in this Chapter, the general requirements for steel ships are to be applied.
3. The requirements in this Chapter are framed for tankers with machinery aft, having one or more rows of longitudinal bulkheads, single decks, single bottoms and longitudinal framing.
4. In tankers intended to carry liquid cargoes other than crude oil and petroleum products, having the vapour pressure (absolute pressure) less than 0.28 MPa at 37.8°C and having no hazard as poisonous, corrosive, etc. and moreover less inflammability than that of crude oil and petroleum products, the structural arrangements and scantlings are to be to the satisfaction of the Society, having regard to the properties of the cargoes to be carried. **【See Guidance】**
5. Notwithstanding the each requirement, the application of below requirements may be exempted in accordance with the requirement of flag state.
  - (1) **103. 5**
  - (2) **107.**
  - (3) **204.**

#### 102. Arrangement of bulkheads **【See Guidance】**

In cargo oil tanks, longitudinal and transverse oiltight bulkheads and wash bulkheads are to be arranged suitably.

#### 103. Cofferdams **【See Guidance】**

1. Cofferdams of airtight construction and of sufficient width as required for ready access are to be provided at the forward and after ends of cargo oil spaces and between cargo oil spaces and accommodation spaces. In tankers intended to carry oils having a flashpoint exceeding 60°C, however, the preceding requirements may be modified.
2. The cofferdams described in the preceding paragraph may be used as pump rooms.
3. Ullage plugs, sighting ports and tank cleaning openings are not to be arranged in enclosed spaces.
4. Fuel oil or ballast water tanks may be concurrently used as the cofferdams to be provided between cargo oil tanks and fuel oil or ballast water tanks, subject to the approval by the Society.
5. Location and separation of spaces in tankers of 500 tons gross and above carrying oils having a flashpoint not exceeding 60°C are to be in accordance with the requirements in **Pt 8, Ch 2, Sec 4.**

#### 104. Airtight bulkheads **【See Guidance】**

Airtight bulkheads are to be provided for the isolation of all cargo oil pumps and pipings from spaces containing stoves, boilers, propelling machinery, electric installations other than those of explosion-proof type specified in **Pt 6, Ch 1, Sec 9** or machinery space where source of ignition is normally present. In tankers carrying oils having a flashpoint exceeding 60°C, however, the preceding requirements may be modified.

#### 105. Ventilation

1. Efficient ventilation is to be provided in spaces adjacent to cargo oil tanks. Air holes are to be cut

in every part of the structure where there might be a chance of gases being "pocketed".

2. Efficient means are to be provided for cleaning oil tanks and pump rooms of dangerous vapours by means of mechanical ventilation or by steam.
3. Ventilation systems of mechanical extraction type are to be provided for the cargo oil pump room specified in **Par 2**. The outlets of exhaust ducts are to be led to the safe position above the open deck and to be fitted with wire mesh screens with mesh of suitable size. This ventilation systems are to be capable of circulating sufficient air to give at least 20 air changes per hour for the total volume of the pump room to prevent accumulation of cargo vapours. The ventilation fan is to be of non-sparking construction. Also the ducts are to be arranged, to permit ventilation from the vicinity of the pump room bilge, above the transverse floor plate or bottom longitudinals. An emergency intake located nearly 2 m above the pump room lower grating is to be arranged to the ducts, and this emergency intake is to have a damper which is capable of being opened or closed from the weather deck and lower grating level.
4. In tankers carrying oils having a flashpoint above 60°C, the capacity of ventilation in the pump rooms specified in **Par 3** may be modified.
5. The requirements in **Par 3** are applied to the ventilation fans and wire mesh screen for the spaces adjacent to the cargo oil tank specified in **Par 1**.

### 106. Openings for ventilation

Ventilation inlets and outlets are to be arranged so as to minimize the possibilities of vapours of cargoes being admitted to an enclosed space containing a source of ignition, or collecting in the vicinity of deck machinery and equipment which may constitute an ignition hazard. Especially, openings of ventilation for machinery spaces are to be situated as far afterwards apart from the cargo spaces as practicable.

### 107. Openings of superstructure and deckhouse

The arrangement of openings on the boundaries of superstructure and deckhouse are to be such as to minimize the possibility of accumulation of vapours of cargoes. Due consideration in this regard is to be given when the ship is equipped to load or unload at the stern. Side scuttles to the poop front or other similar walls are to be of fixed type. Such openings of tankers of 500 gross tons and above carrying oils having a flash point not exceeding 60°C are to be in accordance with the requirements in **Pt 8, Ch 2, 402**.

### 108. Thickness of structural members in cargo oil spaces **[See Guidance]**

The thickness of structural members in cargo oil spaces is to be in accordance with the following:

- (1) The shell plating is not to be of less thickness than that obtained from the formulae in **Ch 4, 302., 304., 402., 403. and 404.** using 2.0 instead of 1.5 in the formulae.
- (2) The deck plating of freeboard deck is not to be of less thickness than that obtained from the formulae in **Ch 5, 301.** using 2.0 instead of 1.5 in the formulae.
- (3) Where frames, beams, stiffeners and other members for which the scantlings are specified by the section modulus only consist of flanged plates, special sections of web and face plates, the thickness of web plates is not to be less than that obtained from the following formula. Where the depth of web plates, however, is specially made deeper due to other reasons than of strength, the preceding requirements may be modified.

$$t = 0.015d_0 + 2.5 \text{ (mm)}$$

where:

$d_0$  = depth of web plates (mm)

- (4) The thickness of various girders, longitudinal, transverse, vertical or horizontal, the cross ties and end connecting brackets thereof and various bulkhead platings is not to be less than 8 mm.
- (5) The thickness of flat bars, tripping brackets, etc. fitted up on webs of longitudinal girders, transverses and stiffeners of bulkheads is not to be less than that obtained from the following formula. The thickness, however, need not exceed that of web plates to which they are connected.

$$t = 0.5\sqrt{L} + 2.5 \text{ (mm)}$$

- (6) In no case is the thickness of structural members to be less than 7 mm.

## Section 2 Hatchways, Gangways and Freeing Arrangements

### 201. Ships having unusually large freeboard **【See Guidance】**

Relaxation from the requirements specified hereunder will be considered to ships having an extraordinarily large freeboard.

### 202. Hatchways to cargo oil tanks (2018)

1. The thickness of coaming plates is not to be less than 10 mm. Where the length and coaming height of a hatchway exceed 1.25 m and 760 mm respectively, vertical stiffeners are to be provided to the side or end coamings and the upper edge of coamings is to be suitably stiffened.
2. Hatchway covers are to be of steel or other approved materials. The construction of steel hatchway covers is to comply with the following requirements. The construction of hatchway covers of materials other than steel is to be in accordance with the discretion of the Society. **【See Guidance】**
  - (1) The thickness of cover plates is not to be less than 12 mm. In ships not more than 60 m in length, however, the requirement may be modified.
  - (2) Where the area of a hatchway exceeds 1 m<sup>2</sup> but does not exceed 2.5 m<sup>2</sup>, cover plates are to be stiffened by flat bars of 100 mm in depth spaced not more than 610 mm apart. Where, however, the cover plates are 15 mm or more in thickness, the stiffeners may be dispensed with.
  - (3) Where the area of a hatchway exceeds 2.5 m<sup>2</sup>, cover plates are to be stiffened by flat bars of 125 mm in depth spaced not more than 610 mm apart.
  - (4) The covers are to be secured by fastenings spaced not more than 457 mm apart in circular hatchways or 380 mm apart and not more than 230 mm from the corners in rectangular hatchways.

### 203. Hatchways to spaces other than cargo area (2021)

In exposed positions on the freeboard and forecastle decks or on the top of expansion trunks, hatchways serving spaces other than cargo oil tanks, ballast tank, fuel oil tank and other tanks are to be provided with steel weathertight covers having scantlings complying with the requirements in Ch 19.

### 204. Permanent gangway and passage

1. A fore and aft permanent gangway complying with the requirements of **Pt 4, Ch 4, 503.** is to be provided at the level of the superstructure deck between the midship bridge or deck house and the poop or aft deck house, or equivalent means of access is to be provided to carry out the purpose of the gangway, such as passage below deck. Elsewhere and in ships without midship bridge or deck house, arrangements to the satisfaction of the Society are to be provided to safeguard the crew in reaching all parts used in the necessary work of the ship. **【See Guidance】**
2. Safe and satisfactory access from the gangway level is to be available between crew accommodations and machinery space or between separated crew accommodations spaces.

### 205. Freeing arrangements **【See Guidance】**

1. Ships with bulwarks are to have open rails fitted for at least a half of the length of the exposed part of the freeboard deck or to have other effective freeing arrangements. The upper edge of sheer strake is to be kept as low as practicable.
2. Where superstructures are connected by trunks, open rails are to be provided for the whole length of the exposed parts of the freeboard deck.

### Section 3 Longitudinal Frames and Beams in Cargo Oil Spaces

#### 301. General

Longitudinal frames and beams provided in permanent ballast water tanks and such spaces that cargo oil is loaded including void spaces and pump rooms are to be in accordance with the requirements stated hereunder.

#### 302. Scantlings

- The section modulus of bottom longitudinals and side longitudinals including bilge frames is not to be less than that obtained from the formulae given in **Table 10.23.1**.

**Table 10.23.1 Section modulus of bottom and side longitudinals**

Positions	Section modulus (cm <sup>3</sup> )								
	Bottom longitudinals	Side longitudinals including bilge frames							
Midship part and between a point 0.15 L from the fore end and the collision bulkhead	$Z = 10Shl^2$	$Z = 9.3Shl^2$ $Z_{\min} = 3.2\sqrt{L}Sl^2$	However, this value need not exceed the requirements for the bottom longitudinals and it may be suitably modified for side longitudinals within 0.25 D from a point of 0.5 D above the top of keel.						
Forward and afterward end parts	$Z = 8.5Shl^2$	$Z = 7.9Shl^2$ $Z_{\min} = 2.72\sqrt{L}Sl^2$							
<p><math>l</math> = spacing of bottom transverses (m)  <math>S</math> = spacing of bottom longitudinals (m)  <math>h</math> = distance from the longitudinal under consideration to the point of <math>h'</math> above the top of keel (m)  <math>h'</math> = as specified in the following table</p> <table border="1" style="margin-left: auto; margin-right: auto;"> <thead> <tr> <th></th> <th><math>h'</math> (m)</th> </tr> </thead> <tbody> <tr> <td>Bottom longitudinals</td> <td><math>h' = d + 0.026L</math></td> </tr> <tr> <td>Side longitudinals including bilge frames</td> <td><math>h' = d + 0.044L - 0.54</math></td> </tr> </tbody> </table>					$h'$ (m)	Bottom longitudinals	$h' = d + 0.026L$	Side longitudinals including bilge frames	$h' = d + 0.044L - 0.54$
	$h'$ (m)								
Bottom longitudinals	$h' = d + 0.026L$								
Side longitudinals including bilge frames	$h' = d + 0.044L - 0.54$								

- The section modulus of longitudinal beams is not to be less than 1.1 times that obtained from the formula in **Ch 10, 303**.
- Notwithstanding the provisions in **Par 1** and **Par 2**, the section modulus of longitudinal frames and beams is not to be less than obtained assuming them as stiffeners on deep tank bulkhead and taking the distance from the longitudinal frames or longitudinal beams to the top of hatchways as  $h$ .
- Longitudinal beams and side longitudinals attached to the sheer strake are to be of such dimensions as slenderness ratio not exceeding 60 at the midship part as far as practicable.
- As for flat bars used for longitudinal beams and frames, the ratio of depth to thickness is not to exceed 15.
- The extreme width of face plates of longitudinal beams and frames is not to be less than that obtained from the following formula:

$$b = 2.2\sqrt{d_0 l} \text{ (mm)}$$

where:

$d_0$  = depth of web of longitudinal beams or frames (mm)

$l$  = spacing of transverses (m)

### 303. Attachment

Longitudinal frames and beams are to be continuous or to be attached at their ends in such a manner as to effectively develop the sectional area and the resistance to bending.

## Section 4 Girders and Transverses in Cargo Oil Spaces

### 401. General

1. The requirements specified hereunder are framed for structures consisting of two to five transverses arranged at approximately equal intervals between transverse bulkheads or between the transverse bulkhead and the wash bulkhead.
2. Girders or transverses in the same plane are to be so arranged that abrupt change in the strength and rigidity is avoided; they are to have brackets of sufficient scantlings and with properly rounded corners at their ends.
3. The depth of girders or transverses is not to be less than 2.5 times that of slots for frames, beams and stiffeners.
4. As for the face plates composing girders, the thickness is not to be less than that of web plates and the width of the face plates is not to be less than that obtained from the following formula:

$$b = 2.7\sqrt{d_0 l} \quad (\text{mm})$$

where:

$d_0$  = depth of girder (mm). In case where it is a balanced girder,  $d_0$  is the depth from the surface of plate to the face plate (mm)

$l$  = distance between supports of girder (m). Where, however, effective tripping brackets are provided, they may be taken as supports.

5. The requirements in this Section are also to be applied to pump rooms, ballast water tanks or void spaces in the midship part as far as practicable.

### 402. Transverses in cargo oil spaces

1. The depth and section modulus of bottom transverses are not to be less than those obtained from the following formulae respectively:

$$\text{Depth : } d = 160l_0 \quad (\text{mm})$$

$$\text{Section modulus : } Z = 9.7 k^2 (d + 0.026L) S l_0^2 \quad (\text{cm}^3)$$

where:

$l_0$  = overall length of transverses (m), which is equal to the distance from the inner surface of face plates of side transverses to the inner surface of face plates of vertical webs on the centre line bulkhead (See **Fig 10.23.1**)

$S$  = spacing of transverses (m)

$k$  = correction factor due to bracket given by the following formula :  $k = 1 - \frac{0.65(b_1 + b_2)}{l_0}$

$b_1, b_2$  = arm length of brackets at both ends of transverses (m) (See **Fig 10.23.1**)

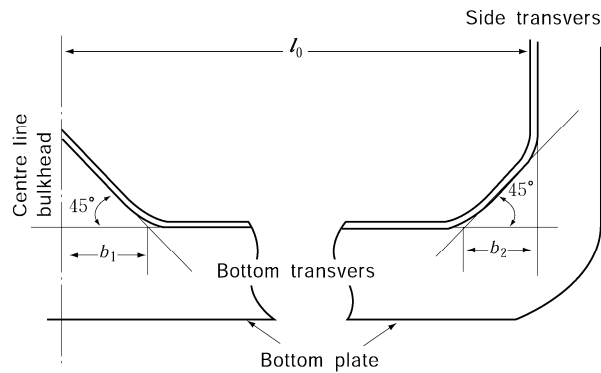

Fig 10.23.1 Measurement of  $b_1$ ,  $b_2$ , and  $l_0$

2. The depth and section modulus of side transverses are not to be less than those obtained from the following formulae respectively.

Depth :  $d = 150l_0$  (mm)

Section modulus :  $Z = 8.7k^2Shl_0^2$  (cm<sup>3</sup>)

where:

$l_0$  = overall length of side transverses (m), which is equal to the distance between the inner surfaces of face plates of bottom transverses and deck transverses

$S$  = spacing of transverses (m)

$h$  = distance from the mid-point of  $l_0$  to the point of  $h = d + 0.044L - 0.54$  above the top of keel (m)

$k$  = correspondingly as specified in **Par 1**

3. The section modulus of transverses at bilge is not to be less than that obtained from the following formula. However, in calculating the section modulus of transverses, the neutral axis of section is to be assumed as to situate at the mid-point of the depth of transverses. (See **Fig 10.23.2**).

$Z = 7.8Shl_0^2$  (cm<sup>3</sup>)

where:

$S$ ,  $h$ ,  $l_0$  = as specified in **Par 2** respectively

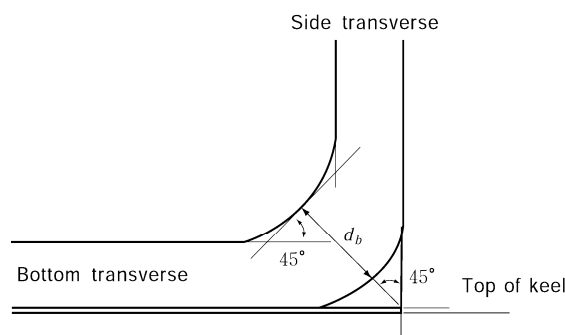

Fig 10.23.2 Measurement of  $d_b$

4. The depth and section modulus of deck transverses are not to be less than those obtained from the following formulae respectively:

$$\text{Depth of transverses : } d = 100l_0 \text{ (mm)}$$

$$\text{Section modulus of transverses : } Z = 1.82k^2\sqrt{L}Sl_0^2 \text{ (cm}^3\text{)}$$

where:

$l_0$  = overall length of deck transverse (m), which is equal to the distance between the inner surface of face plate of side transverses and the centre line bulkhead

$S$  = spacing of transverses (m)

$k$  = as specified in **Par 1**

5. As for vertical webs provided on the centre line bulkhead, the requirements in **Par 2** for side transverses are to be correspondingly applied, but the depth and section modulus are not to be less than obtained from the formulae with each coefficient multiplied by 0.8 respectively.

## Section 5 Trunks

### 501. Construction and scantlings

1. In ships with trunks, deck transverses extending from side to side of the ship across the trunk are to be provided as far as practicable. In this case, the depth of deck transverses regarded as being supported by trunks may be 0.03  $B$ .
2. Trunks are to be provided with stiffening transverses in line with the deck transverses. The section modulus of stiffening transverses is not to be less than that obtained from the following formula:

$$Z = 1.4\sqrt{L}Sl^2 \text{ (cm}^3\text{)}$$

where:

$l$  = half breadth of trunks (m)

$S$  = spacing of transverses (m)

3. The thickness of trunk top and side plating is not to be less than that obtained from the following formula:

$$t = 6.5S + 2.0 \text{ (mm)}$$

where:

$S$  = spacing of longitudinal stiffeners (m)

4. The section modulus of longitudinal stiffeners provided on trunks is not to be less than that obtained from the following formula:

$$Z = 2\sqrt{L}Sl^2 \text{ (cm}^3\text{)}$$

where:

$l$  = spacing of transverses (m)

$S$  = spacing of longitudinal stiffeners (m)

5. Both ends of trunk are to be sufficiently stiffened for the continuity of strength.

## Section 6 Bulkheads in Cargo Oil Space

### 601. Thickness of bulkhead plating

1. The thickness of bulkhead plating is not to be less than obtained from the formula in **Ch 15** for deep tank bulkhead plating, using  $h$  measured from the lower edge of plating to the top of hatches (m) or  $0.3\sqrt{L}$  (m), whichever is the greater.
2. The breadth of the uppermost and lowest strakes of longitudinal bulkhead plating is not to be less than  $0.1 D$  and the thickness of these is not to be less than that obtained from the following formulae:

$$\text{For the lowest strakes : } t = 1.1S\sqrt{L} + 2.5 \text{ (mm)}$$

$$\text{For the uppermost strakes : } t = 0.8S\sqrt{L} + 2.5 \text{ (mm)}$$

where:

$S$  = spacing of stiffeners (m)

### 602. Stiffeners

1. The section modulus of stiffeners is not to be less than that obtained from the formula in **Ch 15** for deep tank bulkhead stiffeners, using  $h$  measured from the midpoint of  $l$  in case of vertical stiffeners or from the centre of the width of plating supported by the stiffener in case of horizontal stiffeners to the top of hatches (m) or  $0.3 \sqrt{L}$  (m), whichever is the greater.
2. Horizontal stiffeners provided on upper and lower parts of longitudinal bulkhead plating are to be of increased scantlings above those specified in the preceding paragraph.
3. The full width of face plates of horizontal stiffeners on longitudinal bulkhead is not to be less than required in **302. 6**.

### 603. Additional strengthening of bulkhead in large tanks

Additional strengthening of bulkhead in large tanks is to be as required by the Society. **【See Guidance】**

### 604. Wash bulkheads

1. Stiffeners and girders are to be of adequate strength in conformity with the size and opening ratio of tanks.
2. The thickness of bulkhead plating is not to be less than that required by **108. (4)** or obtained from the following formula, whichever is the greater. The thickness of the lowest strake of transverse wash bulkheads is to be properly increased.

$$t = 0.3S\sqrt{L + 150} + 2.5 \text{ (mm)}$$

where:

$S$  = spacing of stiffeners (m)

3. It is recommended that a special consideration be given to the thickness of wash bulkhead plating to prevent the plating from shear buckling. ↓

## CHAPTER 24 DOUBLE HULL TANKERS

### Section 1 General

#### 101. Application **【See Guidance】**

1. The requirements in this Chapter are applied to tankers with machinery aft having one or more longitudinal bulk heads and single decks with double bottom or with double hull structures. Where, tanker means a ship intended to carry crude oil, petroleum products having a vapour pressure (absolute pressure) less than 0.28 MPa at 37.8°C or other similar liquid cargoes in bulk.
2. The construction, equipment and scantlings of ships intended to carry liquid cargoes having a vapour pressure (absolute pressure) less than 0.28 MPa at 37.8°C in bulk other than crude oil and petroleum products are to be the satisfaction of the Society, having regard to the properties of the cargoes to be carried.
3. In case where the construction differs from that specified in **Par 1** and the requirements in this Chapter are considered to be not applicable, matters are to be determined as deemed appropriate by the Society. **【See Guidance】**
4. Except where specially required in this Chapter, is to be complied with the requirement in Chapter concerned.
5. In addition to the requirements specified in Par 4 the relevant requirements in **Pt 7, Ch 1, Sec 10** and **Sec 11** and **Pt 8, Ch 2, Sec 4** are to be applied to ships specified in **Par 1**.
6. Notwithstanding the each requirement, the application of below requirements may be exempted in accordance with the requirement of flag state.
  - (1) **102. 2.** and **3.**
  - (2) **1004.**

#### 102. Arrangement and separation of spaces **【See Guidance】**

1. In cargo oil spaces, longitudinal and transverse oil-tight bulkheads and swash bulkheads are to be suitably arranged.
2. Cofferdams are to be provided in accordance with the following (1) to (3):
  - (1) Cofferdams of air-tight construction with 600 mm and over in width for access are to be provided at fore and aft terminations of cargo oil spaces and the space between the cargo space and accommodation space. Where, however, for oil tankers intended to carry cargo oil having a flashpoint above 60°C, the preceding requirements may be suitably modified.
  - (2) Cofferdams specified in (1) may be used as pump rooms.
  - (3) Fuel oil or ballast water tanks may be concurrently used as the cofferdams subject to the approval by the Society.
3. Passageways leading to cargo areas are to be provided in accordance with the following (1) through (4):
  - (1) Access to cofferdams, ballast tanks, cargo oil tanks and other spaces in the cargo area are to be direct from the open deck and such as to ensure their complete inspection. Access to double bottom spaces may be through a cargo pump room, pump room, deep cofferdam, pipe tunnel or similar compartments, subject to consideration of ventilation aspects.
  - (2) For access through horizontal openings, hatches or manholes, the dimensions are to be sufficient to allow a person wearing a self contained air breathing apparatus and protective equipment to ascend or descend any ladder, without obstruction and also to provide a clear opening to facilitate the hoisting of an injured person from the bottom of the space. The minimum clear opening is not to be less than 600 mm × 600 mm.
  - (3) For access through vertical openings, or manholes providing passage through the length and breadth of the space, the minimum clear opening should be not less than 600 mm × 800 mm at a height of not more than 600 mm from the bottom shell plating unless gratings or other footholds are provided.
  - (4) For tankers with a deadweight tonnage of less than 5,000 tons, smaller dimensions of minimum clear opening specified in (2) and (3) may be approved by the Society in special circumstances, if the ability to traverse such openings or to remove an injured person can be proved to the

satisfaction of the Society.

#### 4. Airtight bulkhead

All areas, where cargo oil pumps and cargo oil piping are provided, are to be segregated by an air-tight bulkhead from areas where stoves, boilers, propelling machinery, electric installations other than those of explosion-proof type in accordance with the requirements in **Pt 6, Ch 1, Sec 9** or machinery where source of ignition is normally present. Where, however, for oil tankers carrying cargo oil having a flashpoint above 60°C the requirements may be suitably modified.

#### 5. Ventilation inlets and outlet

Ventilation inlets and outlets are to be arranged so as to minimize the possibilities of vapours of cargoes being admitted to an enclosed space containing a source of ignition, or collecting in the vicinity of deck machinery and equipment which may constitute an ignition hazard. Especially, openings of ventilation for machinery spaces are to be situated as far afterwards apart from the cargo spaces as practicable.

6. Ullage openings, sighting ports and tank cleaning openings are not to be arranged in enclosed spaces.

#### 7. Openings on the boundaries of superstructures and deckhouses

The arrangement of openings on the boundaries of superstructures and deckhouses are to be such as to minimize the possibility of accumulation of vapours of cargoes. Due consideration in this regard is to be given for the openings in superstructures and deckhouses when the ship is equipped with cargo piping to load or unload at the stern.

#### 8. Pipe duct in double bottom

Pipe ducts in the double bottom are to comply with the following requirements:

- (1) They are not to communicate with the engine room.
- (2) Provision is to be made for at least two exits to the open deck arranged at a maximum distance from each other. One of these exits fitted with a watertight closure may lead to the cargo pump room.
- (3) In the duct, provision is to be made for adequate mechanical ventilation.
- (4) For ships to which the convention applies, refer to SOLAS 1974(as amended) Regulation II-2/4, 5.2.4.

### 103. Minimum thickness 【See Guidance】

1. The thickness of structural members in cargo oil tanks and deep tanks such as bulkhead platings, floors, girders including struts and their end brackets is not to be less than 8 mm.
2. In no case is the thickness of structural members in cargo oil tanks and deep tanks other than structural members in **Par 1** to be less than 7 mm.

## Section 2 Bulkhead Plating

### 201. Bulkhead plating of cargo oil tanks and deep tanks

1. Thickness of bulkhead plating is not to be less than that obtained from the following formula :

$$t = 3.6S\sqrt{h} + 2.5 \quad (\text{mm})$$

where :

$S$  = spacing of stiffeners (m)

$h$  = a head of water  $h_1$  or  $h_3$  as given in **Table 10.24.1** which is the greater. When the ship use the flow-through ballast water exchange operations method,  $h_4$  is to be additionally considered.

Table 10.24.1 A head of water (2020)

	Cargo Oil Tank	Deep Tank
$h_1$	Vertical distance from the lower edge of the bulkhead plating under consideration to the top of hatchway. For bulkheads of large tanks, a suitable water head given in Pt 3, Ch 15 is to be considered.	Vertical distance from the lower edge of the bulkhead plating under consideration to the midpoint between the point on tank top and the upper end of the overflow pipe. For bulkheads of large tanks, suitable water head given in Pt 3, Ch 15 is to be considered,
$h_3$	$0.3\sqrt{L}$ (m)	0.7 times the vertical distance from the lower edge of the bulkhead plating under consideration to the point 2.0 m above the top of overflow pipe
$h_4$	–	Vertical distance from the lower edge of the bulkhead plating under consideration to the top of the overflow pipe (or air pipe) to the point where the overpressure is added (m). (Overpressure : due to sustained liquid flow through overflow pipe in case of overfilling or filling during flow through ballast water exchange. It is to be defined by the designer, but not to be less than 2.5.) For bulkheads of large tanks, suitable water head given in Pt 3, Ch 15 is to be considered,

- For the uppermost and lowermost plating of longitudinal bulkheads, the breadth is not to be less than  $0.1 D$ , and the thickness is not to be less than that obtained from the following formulae:

$$\text{Lowermost plating : } t = 1.1S\sqrt{L} + 2.5 \quad (\text{mm})$$

$$\text{Uppermost plating : } t = 0.85S\sqrt{L} + 2.5 \quad (\text{mm})$$

where

$S$  = spacing of stiffeners (m)

## 202. Swash bulkheads [See Guidance]

- Stiffeners and girders are to be of sufficient strength deemed appropriate by the Society considering the size of tanks and opening ratios.
- Thickness of bulkhead plating is not to be less than that obtained from the following formula:

$$t = 0.3S\sqrt{L+150} + 2.5 \quad (\text{mm})$$

where:

$S$  = spacing of stiffeners (m)

- In determining the thickness of swash bulkhead plating, sufficient consideration is to be given for buckling.

## 203. Trunks

- The thickness of trunk top plating and side wall plating are to be obtained applying the requirements in **Ch 5** in addition to the requirements in **201**.
- Both ends of trunk are to be sufficiently stiffened for the continuity of strength.

## Section 3 Frames, Stiffeners and Longitudinal Beams

### 301. Longitudinals

1. The section modulus of bottom longitudinals is not to be less than that obtained from the following formula :

$$Z = 8.6 S h l^2 \quad (\text{cm}^3)$$

where:

$l$  = spacing of floors (m)

$S$  = spacing of bottom longitudinals (m)

$h$  = distance from the bottom longitudinals under consideration to a point of  $d + 0.026L$  above top of keel (m)

2. The section modulus  $Z$  of side longitudinals, including bilge longitudinals is to be the greater of that obtained from the following formulae:

$$Z_1 = 8.6 S h l^2 \quad (\text{cm}^3)$$

$$Z_2 = 2.9 \sqrt{L} S l^2 \quad (\text{cm}^3)$$

where

$l$  = spacing of transverses (m)

$S$  = spacing of side longitudinals (m)

$h$  = distance from the side longitudinals under consideration to a point of  $d + 0.044L - 0.54$  above top of keel (m)

3. For the parts forward and afterword of the midship part, the section modulus of side longitudinals may be gradually reduced to 85 % of that obtained from the requirements in **Par 2** at the end parts of the ship in no case longitudinals to be less than required in **Par 2** for the part between a point  $0.15L$  from the fore end and the collision bulkhead.
4. In addition to **Par 1** to **Par 3**, the section modulus of longitudinal frames and beams forming boundaries of deep tank is to be in accordance with the requirements in **302**.

### 302. Bulkhead stiffeners in cargo oil tanks and deep tanks (2020)

1. The section modulus of stiffeners is not to be less than that obtained from the following formula:

$$Z = 7 C S h l^2 \quad (\text{cm}^3)$$

where:

$S$  = spacing of stiffeners (m)

$l$  = overall length between supporting points of stiffeners (m) including the length of connected parts at ends. However, in case where stiffening girders are provided, the distance to the nearest stiffening girder from the connected heel end or the distance between stiffening girders is to be taken.

$h$  = a head of water  $h_1$  or  $h_3$  as specified in **Table 10.24.1** whichever is the greater. Where, however, "from the lower edge of the bulkhead plating under consideration" is to be construed as "from the mid-point of  $l$ " for vertical stiffeners, and as "from the mid-point of the upper and lower stiffeners" for horizontal stiffeners. When the ship use the flow-through ballast water exchange operations method,  $h_4$  as specified in **201. 1.** are to be additionally considered.

$C$  = coefficient given in **Table 10.24.2** according to the type of end connection

Table 10.24.2 Value of *C*

One end of stiffeners The other end of stiffeners	Connection by hard bracket	Connection by soft bracket	Supported by girders or lug connection	Snip
Connection by hard bracket	0.70	1.15	0.85	1.30
Connection by soft bracket	1.15	0.85	1.30	1.15
Supported by girders or lug connection	0.85	1.30	1.00	1.50
Snip	1.30	1.15	1.50	1.50

(NOTES)

1. Connection by hard bracket is a connection by bracket to the double bottoms or to the adjacent members, such as longitudinals or stiffeners in line, of the same or larger sections, or a connection by bracket to the equivalent members mentioned above. (See Fig 10.14.1 (a))
2. Connection by soft brackets is a connection by bracket to the transverse members such as beams or equivalent thereto. (See Fig 10.14.1 (b))

### 303. Buckling strength

1. Buckling strength of longitudinal frames, beams and stiffeners is to be in accordance with the requirements in (1) to (3) below. In case where, the Society specially considers necessary according to the materials, scantlings, geometries and the point of arrangement of these structural members, detailed assessment may be required.
  - (1) Longitudinal beams, side longitudinals attached to the sheer strakes and longitudinal stiffeners attached to the longitudinal bulkhead within 0.1 *D* from the strength deck are to have a slenderness ratio not exceeding 60 at the midship part as far as practicable.
  - (2) As for flat bars used for longitudinal beams, frames and stiffeners, the ratio of depth to thickness is not to exceed 15.
  - (3) The full width of face plates of longitudinal beams, frames and stiffeners is not to be less than that obtained from the following formula:

$$b = 2.2\sqrt{d_0 l} \quad (\text{mm})$$

where:

$d_0$  = depth of web of longitudinal beams, frames or stiffeners (m)

$l$  = spacing of transverses (m)

2. In case where flanged plates other than flat bars are used for frames, longitudinal beams or stiffeners in cargo oil tanks and deep tanks whose scantlings are specified only in terms of section modulus, the thickness of webs is not to be less than that obtained from the following formula. In case where, however, the depth of webs is intended to be greater than the required level due to reasons other than strength, it may be suitably modified.

$$t = 0.015d_0 + 2.5 \quad (\text{mm})$$

where:

$d_0$  = depth of web (mm)

## Section 4 Structural Members in Double Bottoms

### 401. Scantlings of girders and floors

The arrangements and scantlings of girders, floors and various structural members connected to them provided in double bottoms are to be in accordance with the relevant requirements in **Ch 7** in addition to the requirements in this Chapter.

### 402. Other structural members

Structural members other than specified in **401.** are to be in accordance with the requirements in **Ch 7** in addition to the requirements in this Chapter.

## Section 5 Structural Members in Double Side Hull

### 501. Arrangement

1. In case where a ship is provided with double side hull, the width of the double side hull is not to be less than 760 mm.
2. In double side hull, transverses are to be provided at a spacing not exceeding about 3.5 m.
3. In addition to the requirements in **Par 2**, the following spaces are to be provided with transverses:
  - (1) Spaces where solid floors are provided in double bottom
  - (2) Side of transverse bulkheads

### 502. Thickness of transverses

Thickness of transverses is not to be less than that obtained from the following formulae:

$$\text{Transverse system : } t = 0.6\sqrt{L} + 1.5 \quad (\text{mm})$$

$$\text{Longitudinal system : } t = 0.7\sqrt{L} + 1.5 \quad (\text{mm})$$

### 503. Lightening holes

Within about  $0.2D$  from inner bottom plating, the diameter of lightening holes provided in transverses in the middle half length of cargo oil tank is not to exceed about  $1/5$  of the width of transverses. However, if adequate reinforcements are provided, this requirements may be suitably modified for cases where the length of cargo oil tank is especially short.

## Section 6 Girders and Transverses in Cargo Oil Tanks and Deep Tanks

### 601. Scantlings (2020)

1. The section modulus of girders is not to be less than that obtained from the following formula:

$$Z = 7.13 S h l^2 \quad (\text{cm}^3)$$

where:

$S$  = breadth of area supported by girders (m)

$l$  = overall length of girder (m), which is equal to the distance between the inner surfaces of face plates of girders

$h$  = a head of water  $h_1$  or  $h_3$  as specified in **Table 10.24.1** whichever is the greater. Where, however, "from the lower edge of the bulkhead Plating under consideration" is to be construed as "from the mid-point of  $S$ " for horizontal girders, and as "from the mid-point of  $l$ "

for vertical girders. When the ship use the flow-through ballast water exchange operations method,  $h_4$  as specified in **201. 1.** are to be additionally considered.

2. Moment of inertial of girders is not to be less than that obtained from the following formula. However, the depth of girders is not to be less than 2.5 times the depth of slots.

$$I = 30hl^4 \quad (\text{cm}^4)$$

where:

$h, l$  = as specified in **Par 1**

3. Thickness of girders is not to be less than that obtained from the following formula:

$$t = 10S_1 + 2.5 \quad (\text{mm})$$

where:

$S_1$  = spacing of stiffeners or depth of girders, whichever is the smaller (m)

4. Thickness of flat bar stiffeners and tripping brackets provided on girders, transverses and stiffeners attached to bulkhead is not to be less than obtained that from the following formula. However, it needs not exceed the thickness of webs of the girder to which they are provided.

$$t = 0.5\sqrt{L} + 2.5 \quad (\text{mm})$$

5. The thickness of face plates forming a girder is not to be less than the thickness of webs, and the full width is not to be less than that obtained from the following formula:

$$b = 2.7\sqrt{d_0l} \quad (\text{mm})$$

where

$d_0$  = depth of girder (m). In case where girders are of the balanced girder type, depth from the plate surface to face plate (m)

$l$  = distance between supporting points of girder. In case where, however, effective tripping brackets are provided, they may be regarded as supporting points.

## 602. Side transverses for ships without double side hull

1. In addition to the requirements in **601. 1** depth and the section modulus of side transverses in areas carrying cargo oil are not to be less than the value obtained from the following formulae respectively, where, however, the depth of side transverses is not to be less than 2.5 times the depth of slots:

$$d_0 = 0.15l_0 \quad (\text{m})$$

$$Z = 8.7k^2Shl_0^2 \quad (\text{cm}^3)$$

where:

$l_0$  = overall length of side transverses (m), which is equal to the distance between the inner surfaces of face plates of deck transverses and inner bottom plating

$S$  = spacing of transverse (m)

$h$  = distance from the mid-point of  $l_0$  to a point of  $d + 0.044L - 0.54$  above top of keel (m)

$k$  = correction factor for brackets obtained from the following formula (See **Fig 10.23.1**)

$$k = 1 - \frac{0.65(b_1 + b_2)}{l_0}$$

where :

$b_1, b_2$  = length of bracket arm at ends of transverse (m)

2. For ships with trunks, the construction of providing continuous deck transverses across the trunks is to be considered as the standard. In this case, the depth of deck transverses that can be regarded as those supported by trunks may be 0.03  $B$ .

## Section 7 Strengthened Bottom Forward

### 701. Strengthened area of the forward bottom

The area of strengthened bottom forwards to be in accordance with the requirements in **Ch 4, 404.** and **Ch 7, Sec 9.**

## Section 8 Structural Details

### 801. General

1. The principal structural members are to be arranged so that continuity of strength can be secured throughout the cargo area. In forward and afterword parts of the cargo area, the structures are to be effectively strengthened so that continuity of strength is not impaired sharply.
2. For the principal structural members, sufficient consideration is to be given for fixity at ends, supporting and stiffening systems against out-of plane deflections, and the construction is to minimize local stress concentrations.

### 802. Frames and stiffeners

Longitudinal beams, frames and stiffeners are to be of continuous structures, or to be connected securely so that their sectional areas at ends can be properly maintained providing sufficient resistance against bending moments.

### 803. Girders and cross ties

1. Girders provided within the same plane are to be arranged to avoid sharp changes in strength and rigidity, and brackets in suitable size are to be provided at the ends of girders, and bracket toes are to be sufficiently rounded.
2. In case where the depth of longitudinal girders is large, stiffeners are to be arranged in parallel with face plates.
3. Tripping brackets are to be provided on the web plate transverses at the inner edge of end brackets, etc. and also at proper intervals in order to support transverses effectively.
4. The upper and lower end brackets for transverses and transverses for longitudinal bulkheads and webs in the vicinity are to be suitably stiffened.

## Section 9 Special Requirements for Corrosion

### 901. Thickness of shell plating

1. The thickness of shell plating forming the casing of cargo oil tanks planned to carry ballast water in ships without double side hull is not to be less than a thickness added with 0.5 mm to that obtained from the requirements in **Ch 4.**

2. 0.5 mm may be reduced for the thickness of shell plating when applying the requirements of this Chapter from the thickness obtained from the formula given in **201**.

#### 902. Thickness of deck plating

1. 0.5 mm may be reduced for the thickness of freeboard deck plating when applying the requirements in this Chapter from the obtained by the formula given in **201**.
2. At least 0.5 mm is to be added for the thickness of freeboard deck plating in spaces carrying cargo oil from the thickness obtained by the formula given in **Ch 5**.

#### 903. Thickness of tank top plating

The thickness of tank top plating in cargo oil tanks and deep tanks is not to be less than the thickness corresponding to that obtained from the formula given in **201**, added by 1.0 mm. Such an addition, however, is not required for the thickness of inner bottom plating.

#### 904. Section modulus of longitudinal beams, frames and stiffeners

1. The section modulus of longitudinal beams provided on deck plating in spaces carrying cargo oil is not to be less than 1.1 times that calculated according to the requirements of **302**.
2. The section modulus of frames and stiffeners provided on shell plating and bulkheads forming cargo oil tanks planned to carry ballast water, except the tank to carry ballast water only in heavy weather conditions, is not to be less than the value obtained from the  $Z_1$  in the requirements of **301. 2** using a coefficient as 9.3, and the  $Z_2$  using a coefficient as 3.2 respectively. The section modulus of stiffeners in above mentioned cargo oil tanks is not to be less than 1.1 times that calculated in accordance with the requirements in **302**.

## Section 10 Special Requirements for Hatchways and Permanent Gangways

### 1001. Ships having unusually large freeboard **[See Guidance]**

Relaxation from the requirements in this Section will be considered to ships having an unusually large freeboard.

### 1002. Hatchways to cargo oil tanks *(2018)*

1. The thickness of coaming plates is not to be less than 10 mm. Where the length and coaming height of a hatchway exceed 1.25 m and 760 mm respectively, vertical stiffeners are to be provided to the side or end coamings, and the upper edge of coamings is to be suitably stiffened.
2. Hatch covers are to be of steel or other approved materials. The construction of steel hatch covers is to comply with the following requirements (1) through (4). The construction of hatch covers of materials other than steel is to be in accordance with the discretion of the Society.
  - (1) The thickness of cover plates is not to be less than 12 mm. In ships not exceeding 60 m, in length, however, the requirement may be modified.
  - (2) Where the area of a hatchway exceeds 1 m<sup>2</sup> but does not exceed 2.5 m<sup>2</sup>, cover plates are to be stiffened by flat bars of 100 mm in depth spaced not more than 610 mm apart. Where, however, the cover plates are 15 mm or more in thickness the stiffener may be dispensed with.
  - (3) Where the area of a hatchway exceed 2.5 m<sup>2</sup> cover plates are to be stiffened by flat bars of 125 mm in depth spaced not more than 610 mm apart.
  - (4) The covers are to be secured by fastenings spaced not more than 457 mm apart in circular hatchways or 380 mm apart and not more than 230 mm from the corners in rectangular hatchways.

### 1003. Hatchways to spaces other than cargo area *(2021)*

In exposed positions on the freeboard and forecastle decks or on the top of expansion trunks, hatchways serving spaces other than cargo oil tanks, ballast tank, fuel oil tank and other tanks are

---

to be provided with steel weathertight covers having scantlings complying with the requirements in Ch 19.

#### 1004. Gangway and Access

1. A fore and after permanent gangway complying with the requirements in **Pt 4, Ch 4, 503.** is to be provided at the level of the superstructure deck between the midship bridge or deckhouse and the poop or after deckhouse, or equivalent means of access is to be provided to carry out the purpose of the gangway such as passage below deck. Elsewhere, and in ships without midship bridge and deckhouse, arrangements to the satisfaction of the Society are to be provided to safeguard the crew in reaching all parts used in the necessary work of the ship.
2. Safe and satisfactory access from the gangway level is to be available between crew accommodation spaces and machinery spaces or between separated crew accommodation spaces.
3. Where superstructures are connected by trunks, open rails are to be provided for the whole length of exposed parts of freeboard deck. ↓



**2026**

**Guidance Relating to  
the Rules for the Classification of Steel Ships**

---

**Part 10**

**Hull Structures and Equipment of  
Small Steel Ships**

#### APPLICATION OF THE GUIDANCE RELATING TO THE RULES

This "Guidance Relating to the Rules for the Classification of Steel Ships" (hereafter called as the Guidance Relating to the Rules) is prepared with the intent of giving details as to the treatment of the various provisions for items required the unified interpretations and items not specified in the Rules, and the requirements specified in the Guidance Relating to the Rules are to be applied, in principle, in addition to the various provisions in the Rules.

As to any technical modifications which can be regarded as equivalent to any requirements in the Guidance Relating to the Rules, their flexible application will be properly considered.

**APPLICATION OF PART 10**  
**"HULL STRUCTURE AND EQUIPMENT OF SMALL STEEL SHIPS"**

1. Unless expressly specified otherwise, the requirements in the Guidance apply to ships for which contracts for construction are signed on or after 1 July 2026.
2. The amendments to the Guidance for 2025 edition and their effective date are as follows;

**Effective Date : 1 July 2026 (ships for which the application is submitted)**

---

**CHAPTER 22 EQUIPMENT AND EQUIPMENT NUMBER**

**Section 1 General**

- 101.1 has been amended.

# CONTENTS

<b>CHAPTER 1 GENERAL</b> .....	<b>1</b>
Section 1 Definitions .....	1
Section 2 General .....	1
Section 3 Materials, Welding and Construction .....	3
<b>CHAPTER 2 STEMS AND STERN FRAMES</b> .....	<b>7</b>
Section 1 Stems .....	7
Section 2 Stern Frames .....	7
<b>CHAPTER 3 LONGITUDINAL STRENGTH</b> .....	<b>9</b>
Section 1 General .....	9
Section 2 Bending Strength .....	9
<b>CHAPTER 4 PLATE KEELS AND SHELL PLATINGS</b> .....	<b>11</b>
Section 1 General .....	11
Section 3 Shell Plating for Midship Part of Ship .....	11
Section 4 Shell Plating for End Parts .....	11
Section 5 Side Plating in way of Superstructure .....	12
Section 6 Local Compensation of Shell Plating .....	12
<b>CHAPTER 5 DECKS</b> .....	<b>13</b>
Section 1 General .....	13
Section 2 Effective Sectional Area of Strength Deck .....	13
<b>CHAPTER 7 DOUBLE BOTTOMS</b> .....	<b>15</b>
Section 1 General .....	15
Section 5 Bottom Longitudinals .....	15
Section 6 Inner Bottom Plating and Margin Plates .....	15
Section 9 Construction of Strengthened Bottom Forward .....	15
<b>CHAPTER 8 FRAMES</b> .....	<b>17</b>
Section 1 General .....	17
Section 3 Transverse Hold Frames .....	17
Section 5 Tween Deck Frames .....	17
<b>CHAPTER 9 CANTILEVER BEAM CONSTRUCTION</b> .....	<b>19</b>
Section 3 Connection of Cantilever Beams to Web Frames .....	19
<b>CHAPTER 10 BEAMS</b> .....	<b>21</b>
Section 1 General .....	21
Section 2 Deck Load .....	21

Section 3	Longitudinal Beams .....	21
Section 4	Transverse Beams .....	21
<b>CHAPTER 11</b>	<b>DECK GIRDERS .....</b>	<b>23</b>
Section 1	General .....	23
Section 2	Longitudinal Deck Girders .....	23
<b>CHAPTER 12</b>	<b>PILLARS .....</b>	<b>25</b>
Section 1	General .....	25
Section 2	Scantling of Pillars .....	25
<b>CHAPTER 13</b>	<b>ARRANGEMENTS TO RESIST PANTING .....</b>	<b>27</b>
Section 1	General .....	27
Section 2	Arrangements to resist Panting Forward the Collision Bulkhead .....	27
<b>CHAPTER 14</b>	<b>WATERTIGHT BULKHEADS .....</b>	<b>29</b>
Section 1	Arrangement .....	29
Section 2	Construction .....	29
Section 3	Watertight Doors .....	30
<b>CHAPTER 15</b>	<b>DEEP TANKS .....</b>	<b>31</b>
Section 1	General .....	31
Section 2	Bulkheads of Deep Tanks .....	31
<b>CHAPTER 16</b>	<b>SUPERSTRUCTURES AND DECKHOUSES .....</b>	<b>33</b>
Section 1	General .....	33
Section 3	Access Openings in Superstructure End Bulkheads .....	33
<b>CHAPTER 17</b>	<b>MACHINERY SPACES AND ENGINE CASINGS .....</b>	<b>35</b>
Section 1	General .....	35
Section 2	Main Engine Foundations .....	35
<b>CHAPTER 19</b>	<b>HATCHWAYS AND OTHER DECK OPENINGS .....</b>	<b>37</b>
Section 1	General .....	37
<b>CHAPTER 21</b>	<b>BULWARKS, FREEING PORTS, SIDE SCUTTLES, VENTILATORS AND PERMANENT GANGWAYS .....</b>	<b>39</b>
Section 2	Freeing Ports .....	39
Section 3	Side Scuttles .....	39
<b>CHAPTER 22</b>	<b>EQUIPMENT NUMBER AND EQUIPMENT .....</b>	<b>41</b>
Section 1	General .....	41

**CHAPTER 23 OIL TANKERS ..... 43**  
Section 1 General ..... 43  
Section 2 Hatchways, Gangways and Freeing Arrangements ..... 43  
Section 6 Bulkheads in Cargo Oil Space ..... 43

**CHAPTER 24 DOUBLE HULL TANKERS ..... 45**  
Section 1 General ..... 45  
Section 2 Bulkhead Platings ..... 45  
Section 10 Special Requirements for Hatchways and Permanent Gangways ... 45

## CHAPTER 1 GENERAL

### Section 1 Definitions

#### 101. Application **【See Rule】**

As specified in **Pt 3, Ch 1, 101.** of the Guidance.

#### 102. Length **【See Rule】**

As specified in **Pt 3, Ch 1, 102.** of the Guidance.

#### 104. Breadth **【See Rule】**

As specified in **Pt 3, Ch 1, 104.** of the Guidance.

#### 105. Depth **【See Rule】**

As specified in **Pt 3, Ch 1, 106.** of the Guidance.

### Section 2 General

#### 201. Application **【See Rule】**

1. For the ships classed for coastal service area, reduction for scantlings of the ship is to be as followings.
  - (1) For the requirements of the applicable chapters of Rules, scantlings of structural members may be lightened with the rate specified in **Table 10.1.1**, however, not less than the minimum dimensions specified in **Table 10.1.1**.
  - (2) For the reduction for scantlings of the members not specified in **Table 10.1.1**, it is to be in accordance with the discretion of the Society.
  - (3) When the cargoes loaded on the deck beams or heavy cargoes loaded on inner bottom plates and longitudinals, deep tanks and etc, the reduction for scantlings of the members is not permitted
  - (4) The height of hatch coaming and seals for every access opening may be in accordance with **Table 10.1.2**. However, closures of hatchways are to be in accordance with the discretion of the Society.
  - (5) The equipment number and equipment are to be in accordance with **Ch 22** of the Rules. However, one anchor is to be more than the weight specified in **Table 10.22.1** of the Rules, and another anchor is to be more than 85 % the weight specified in **Table 10.22.1** of the Rules.
2. For the ships classed for smooth water service area, reduction for scantlings of the members is to be as followings.
  - (1) For the requirements of the applicable chapters of Rules, scantlings of structural members may be lightened with the rate specified in **Table 10.1.1**, however, not less than the minimum dimensions specified in **Table 10.1.1**.
  - (2) For the reduction for scantlings of the members not specified in **Table 10.1.1**, it is to be in accordance with the discretion of the Society.
  - (3) When the cargoes loaded on the deck beams or heavy cargoes loaded on inner bottom plates and longitudinals, deep tanks and etc, the reduction for scantlings of the members is not permitted
  - (4) The height of hatch coaming and seals for every access opening may be in accordance with **Table 10.1.2**. However, closures of hatchways are to be in accordance with the discretion of the Society.
  - (5) In case of the cargoes being not loaded on the steel hatch covers, 4.5 mm thick plates may be used for the steel hatch covers.

- (6) The steel hatch covers are to be set up stiffeners in proper space and for not intended to carry cargoes or stores on them, the section modulus of the stiffeners may be properly considered as the scantlings of provisions specified in **Ch 19, 303.** of the Rules.
- (7) The equipment number and equipment are to be in accordance with above **Par 1 (5).** However, for the equipment letters specified in **Table 10.22.1** of the Rules. one lower grade of the letter may be applied according to the equipment number required in **Ch 22, 201.** of the Rules.

**Table 10.1.1 Minimum dimension and lightening of the members**

Item		Coastal services	Smooth water services	Minimum dimension
Longitudinal strength	$M_w$	20 %	30 %	-
	$Z_{min}$	10 %	15 %	-
Shell plating(including plate keels)		5 %	10 %	6 mm, (excluding superstructure)
Plate thick. of deck		1 mm	1 mm	5 mm
Section modulus of frame (including bottom longitudinals)		10 %	20%	30 cm <sup>3</sup>
Section modulus of deck frame		15 %	15 %	-
Section modulus of girder under deck		15 %	15 %	-
Plate thick. of double bottom		1 mm	1 mm	5.5 mm
Plate thick. of single bottom		0.5 mm	10 % or 1 mm whichever is smaller	-
Plate thick. of B.H.D of super. structure end and section modulus of B.H.D stiffener		10 %	10 %	-
(NOTES)				
1. For the ships engaging in international services may not be lightened the thickness of B.H.D of superstructure end and moment of inertia of B.H.D stiffeners.				
2. $Z_{min}$ & $M_w$ : refer to <b>Table 10.3.1</b> of the Rules				

**Table 10.1.2 Height of sills of hatch coaming and other access openings (mm)**

Service area	Type	Normal Hatchway		Small Hatchway (area of hatchway)				Companion ways		Access opening of superstructure end		Ventilation tunnel	
				less than 0.45 m <sup>2</sup>		0.45~1.5 m <sup>2</sup>							
	Ship length Position	less than 30 m	30 m or more	less than 30 m	30 m or more	less than 30 m	30 m or more	less than 30 m	30 m or more	less than 30 m	30 m or more	less than 30 m	30 m or more
Costal service	I	450	600	230	380	380	450	300	450	300	380	760	900
	II	300	450	180	230	230	380	150	300	100	300	450	760
Smooth water service	I	300	450	150	230	230	380	150	300	150	300	450	760*
	II	150	300	100	180	150	230	100	100	100	100	450	450
(NOTES)													
1. For the ships engaging in international services are to be excluded.													
2. * : For the tug boats not engaging in international services, the height of ventilation tunnel may be more than 450 mm.													

**202. Exception in application [See Rule]**

In application to **202.** of the Rules, the term "the discretion of the Society" means the compliance with the direct strength calculation specified in **Pt 3, Ch 1, 206.** of the Rules, or the acceptance in accordance with **Pt 1, Ch 1, 105.** of the Rules.

**203. Ships on unusual form or proportion, or intended for carriage of special cargoes [See Rule]**

As specified in **Pt 3, Ch 1, 203.** of the Guidance.

**208. Equipment [See Rule]**

In application to **208.** of the Rules, the term "the tests as may be required by the Surveyor" means the tests required by related Rules such as **Pt 4, Pt 9** of the Rules.

### Section 3 Materials, Welding and Construction

**301. Materials [See Rule]**

1. As for ships 60 m and above in length, plating materials for stern frames, rudder horns, rudders and shaft brackets are to be used of higher than Grade I of **Table 10.1.3** of the Rules.
2. Where high tensile steels are used, the formulas for thickness of deck and shell platings, the section modulus of stiffeners, and other scantlings etc., are to be in accordance with the requirements of **Pt 3.**
3. Where the local structure of crafts was constructed in aluminium alloy, the material factor is to be in accordance with **Table 10.1.3** to **Table 10.1.6.** But others than the Guidance are to be as following formula;

$$K = \frac{240}{\sigma_f}$$

$\sigma_f$  = yield stress (N/mm<sup>2</sup>, proof load with 0.2% permanent deformation) is not to be taken greater than 70% of the ultimate tensile strength.

**Table 10.1.3 Factor *K* for Wrought Aluminium Alloy Plates**  
(2 mm ≤ t ≤ 40 mm)

Grade	Temper condition	K
A 5052 P	H32	1.64
	H34	1.45
A 5154A P	O, H111	2.86
A 5454 P	H32	1.37
	H34	1.27
A 5086 P	H116, H32	1.25
	H34	1.14
A 5083 P	H116, H321	1.12
(NOTES)		
For temper condition O and H111, the factor <i>K</i> is to be taken from Table 10.1.6.		

**Table 10.1.4 Factor  $K$  for Aluminium Alloy Extruded Shapes**  
(Note : when the main loading direction is longitudinal to the extrusion) ( $2 \text{ mm} \leq t \leq 25 \text{ mm}$ )

Grade	Temper condition	$K$
A 6061 S	T5/T6	1.32
A 6005A S	T5/T6	1.32
A 6082 S	T5/T6	1.11

**Table 10.1.5 Factor  $K$  for Aluminium Alloy Extruded Shapes**  
(Note : when the main loading direction is transverse to the extrusion ) ( $2 \text{ mm} \leq t \leq 25 \text{ mm}$ )

Grade	Temper condition	$K$
A 6061 S	T5/T6	1.41
A 6005A S	T5/T6 $6 \leq t \leq 10$	1.32
	$10 \leq t \leq 25$	1.49
A 6082 S	T5/T6	1.18

**Table 10.1.6 Factor  $K$  in the Welded Condition**

Grade	Temper condition	Welding consumables	$K$
A 5052	O, H111, H32, H34	A 5356 BY/WY	3.70
A 5154A	O, H111	A5356- A5183BY/WY	2.86
A 5454	O, H111, H32, H34	A5356- A5183BY/WY	2.86
A 5086	O, H111, H116, H32, H34	A5356- A5183BY/WY	2.38
A 5083	H116, H321, H116, H321	A 5356 BY/WY	1.89
		A 5183 BY/WY	1.67
A 6061	T5/T6	A5356- A5183BY/WY	2.08
A 6005A	T5/T6	A5356- A5183BY/WY	2.08
A6082	T5/T6	A5356- A5183BY/WY	2.08

4. In application to **301. 4** of the Rules, the term "the discretion of the Society" means the acceptance in accordance with **Pt 1, Ch 1, 105.** of the Rules. 【See Rule】
5. When the stainless steels are used for plate, use of the materials and their scantling are to be complied with **Pt 3, Ch 1, 401. 1.** of the Guidance. (2018)

**302. Scantlings (2021) [See Rule]**

1. Scantlings of stiffeners may be decided based on the concept of grouping designated sequentially placed stiffeners of equal scantlings. The scantling of the group is to be taken as the greater of the following (1) and (2). However, this concept of grouping is not applicable to fatigue requirements.
  - (a) the average of the required scantling of all stiffeners within a group
  - (b) 90 % of the maximum scantling required for any one stiffener within the group. ↕

---

## CHAPTER 2 STEMS AND STERN FRAMES

### Section 1 Stems

#### 101. Plate stems **【See Rule】**

As specified in **Pt 3, Ch 2, 101.** of the Guidance.

### Section 2 Stern Frames

#### 202. Propeller posts **【See Rule】**

1. The welding of cast steel stern frames are to be in accordance with the **Pt 3, Ch 2, 202.** of the Guidance.
2. The connection of cast steel boss and plate parts of built-up stern frame is to be in accordance with the **Pt 3, Ch 2, 203.** of the Guidance.

#### 203. Shoe pieces **【See Rule】**

As specified in **Pt 3, Ch 2, 205.** of the Guidance.

#### 204. Heel pieces **【See Rule】**

As specified in **Pt 3, Ch 2, 206.** of the Guidance. ↓

---

## CHAPTER 3 LONGITUDINAL STRENGTH

### Section 1 General

**101. Special case in application [See Rule]**

As specified in Pt 3, Ch 3, 101. of the Guidance.

**103. Loading manual [See Rule]**

As specified in Pt 3, Ch 3, 103. of the Guidance.

**104. Longitudinal strength loading instrument [See Rule]**

As specified in Pt 3, Ch 3, 104. of the Guidance.

### Section 2 Bending Strength

**201. Bending strength at amidships [See Rule]**

In application to Table 10.3.1 of the Rules, the term "method of calculation deemed appropriate by the Society" means Pt 3, Ch 3, 201. of the Guidance.

**203. Calculation of hull section modulus [See Rule]**

As specified in Pt 3, Ch 3, 203. of the Guidance. ⚡

## CHAPTER 4 PLATE KEELS AND SHELL PLATINGS

### Section 1 General

#### 102. Special consideration for contact with the fishing gear, etc. (2020) 【See Rule】

In cases where the service condition of the ship is considered to be such that there is possibility of indent of shell plating due to contact with the fishing gear etc., special consideration is to be given to the thickness of shell plating. However, the Rules and Guidance 102. may not apply where the shell is protected by suitable accessories such as fenders.

### Section 3 Shell Plating for Midship Part of Ship

#### 303. Sheer strakes for midship part 【See Rule】

As specified in Pt 3, Ch 4, 303. of the Guidance.

### Section 4 Shell Plating for End Parts

#### 401. Shell plating for end parts 【See Rule】

1. The thickness of shell plating of curved parts within  $0.3L$  from the forward and aft end may be calculated with the value of  $S$  taken as equal to 1.1 times the vertical or horizontal distance between frames  $a$  as shown in Fig 10.4.1.

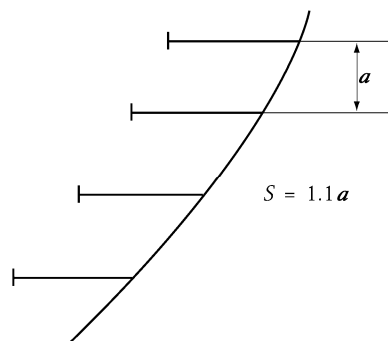
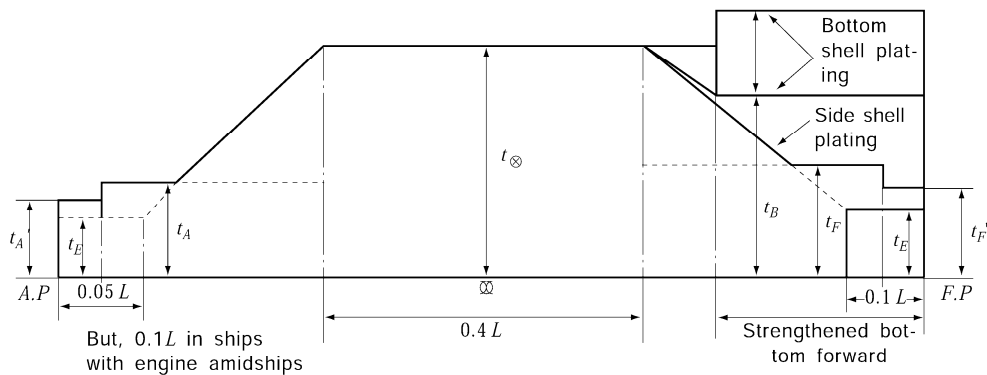

Fig 10.4.1 Relation of  $S$  and  $a$  in end parts

2. The thickness of shell plating is not to be less than the thickness shown in Fig 10.4.2 approximately at the middle of length of each plates.



- $t_{\infty}$  : Required thickness of shell plating in midship part (to be the actual thickness, if actual thickness is greater than required due to assuring the longitudinal strength)
- $t_E$  : Required thickness of shell plating in end parts ( $4.6 + 0.44L$ ) (mm)
- $t_F(t_F)$  : Required thickness of shell plating within  $0.3L$  from the fore end ( $1.34 S\sqrt{L} + t_C$ ) (mm)
- $t_A(t_A)$  : Required thickness of shell plating within  $0.3L$  from the aft end ( $1.20 S\sqrt{L} + t_C$ ) (mm)
- $t_B$  : Required thickness of shell plating in strengthened bottom forward (mm)

Fig 10.4.2 Tapering of shell plating thickness

**404. Strengthened bottom forward [See Rule]**

As specified in Pt 3, Ch 4, 404. of the Guidance.

**Section 5 Side Plating in way of Superstructure**

**503. Compensation at end Superstructure [See Rule]**

As specified in Pt 3, Ch 4, 601. of the Guidance.

**Section 6 Local Compensation of Shell Plating**

**601. Opening in shell [See Rule]**

As specified in Pt 3, Ch 4, 701. of the Guidance.

**602. Thickness of sea chest [See Rule]**

As specified in Pt 3, Ch 4, 702. of the Guidance. ↓

---

## CHAPTER 5 DECKS

### Section 1 General

**101. Steel deck plating [See Rule]**

As specified in Pt 3, Ch 5, 101. of the Guidance.

**102. Watertightness of decks [See Rule]**

As specified in Pt 3, Ch 5, 102. of the Guidance.

**104. Compensation for openings [See Rule]**

As specified in Pt 3, Ch 5, 104. of the Guidance.

**105. Rounded gunwales [See Rule]**

As specified in Pt 3, Ch 5, 105. of the Guidance.

### Section 2 Effective Sectional Area of Strength Deck

**202. Effective sectional area of strength deck [See Rule]**

As specified in Pt 3, Ch 5, 202. of the Guidance.

**204. Long poop [See Rule]**

As specified in Pt 3, Ch 5, 204. of the Guidance.

**205. Superstructure deck designed as strength deck [See Rule]**

As specified in Pt 3, Ch 5, 205. of the Guidance. ⚡

---

---

## CHAPTER 7 DOUBLE BOTTOMS

### Section 1 General

#### 101. Application (2018) 【See Rule】

1. For the ships subject to **SOLAS** or **Korean Ship Safety Act**, and whose gross tonnages are more than 500 and engaged in international service, a double bottom may be omitted provided it is satisfied for requirements of **Pt 3, Ch 7, 101. 1.** of the Guidance.
2. For the ships subject to **Korean Ship Safety Act.**, relevant requirements of Standard for Steel Ship's Hull Structure is to be applied.

### Section 5 Bottom Longitudinals

#### 502. Scantlings 【See Rule】

As specified in **Pt 3, Ch 7, 403. 2** of the Guidance.

### Section 6 Inner Bottom Plating and Margin Plates

#### 601. Thickness of inner bottom plating 【See Rule】

As specified in **Pt 3, Ch 7, 501. 4** of the Guidance.

### Section 9 Construction of Strengthened Bottom Forward

#### 901. Application 【See Rule】

As specified in **Pt 3, Ch 7, 801.** of the Guidance.

#### 902. Strengthened bottom forward 【See Rule】

As specified in **Pt 3, Ch 7, 802.** of the Guidance. ↓

---

---

## CHAPTER 8 FRAMES

### Section 1 General

#### 104. Frames in boiler spaces and in way of bossing **【See Rule】**

In application to **104. 2** of the Rules, the term "the satisfaction of the Society" means the acceptance in accordance with **Pt 1, Ch 1, 105.** of the Rules.

### Section 3 Transverse Hold Frames

#### 301. Application **【See Rule】**

In application to **301. 2** of the Rules, the term "specially considered" means the compliance with **Pt 7, Ch 3, Sec 7** of the Rules, or the acceptance in accordance with **Pt 1, Ch 1, 105.** of the Rules.

#### 302. Scantlings of transverse hold frames **【See Rule】**

As specified in **Pt 3, Ch 8, 302.** of the Guidance.

### Section 5 Tween Deck Frames

#### 502. Scantlings **【See Rule】**

As specified in **Pt 3, Ch 8, 502.** of the Guidance.

#### 503. Special care to tween deck frames **【See Rule】**

As specified in **Pt 3, Ch 8, 503.** of the Guidance. ⚓

---

## CHAPTER 9 CANTILEVER BEAM CONSTRUCTION

### Section 3 Connection of Cantilever Beams to Web Frames

#### 301. Connections **【See Rule】**

As specified in Pt 3, Ch 9, 503. of the Guidance. ↕

---

---

## CHAPTER 10 BEAMS

### Section 1 General

#### 102. Connections of ends of beams **【See Rule】**

As specified in Pt 3, Ch 10, 102. of the Guidance.

### Section 2 Deck Load

#### 201. Value of $h$ **【See Rule】**

1. As specified in Pt 3, Ch 10, 201. of the Guidance.
2. In application to 201. 2 (4) of the Rules, the term "the discretion of the Society" means Pt 3, Ch 1, 203. 2 (2) (C) of the Guidance. **【See Rule】**

### Section 3 Longitudinal Beams

#### 303. Section modulus **【See Rule】**

As specified in Pt 3, Ch 10, 303. of the Guidance.

### Section 4 Transverse Beams

#### 402. Proportion **【See Rule】**

As specified in Pt 3, Ch 10, 402. of the Guidance. ↓

---

## CHAPTER 11 DECK GIRDERS

### Section 1 General

#### 103. Construction **【See Rule】**

As specified in Pt 3, Ch 11, 103. of the Guidance.

#### 104. End connection **【See Rule】**

As specified in Pt 3, Ch 11, 104. of the Guidance.

### Section 2 Longitudinal Deck Girders

#### 201. Section modulus **【See Rule】**

As specified in Pt 3, Ch 11, 201. of the Rules. ↴

---

## CHAPTER 12 PILLARS

### Section 1 General

#### 102. Pillar in holds **【See Rule】**

As specified in Pt 3, Ch 12, 102. of the Guidance.

### Section 2 Scantling of Pillars

#### 201. Sectional area **【See Rule】**

As specified in Pt 3, Ch 12, 201. of the Guidance. ↓

## CHAPTER 13 ARRANGEMENTS TO RESIST PANTING

### Section 1 General

#### 102. Swash Plates **【See Rule】**

As specified in Pt 3, Ch 13, 102. of the Guidance.

#### 103. Stringers fitted up with extremely small angles **【See Rule】**

As specified in Pt 3, Ch 13, 103. of the Guidance.

### Section 2 Arrangements to resist Panting Forward the Collision Bulkhead

#### 201. Constructions and arrangements **【See Rule】**

Where bottom plates of chain lockers, which are located forward collision bulkhead and reach side shell, are not situated in the level of side stringer, horizontal girders are recommended to be fitted in chain lockers at the stringer level. (See Fig 10.13.1)

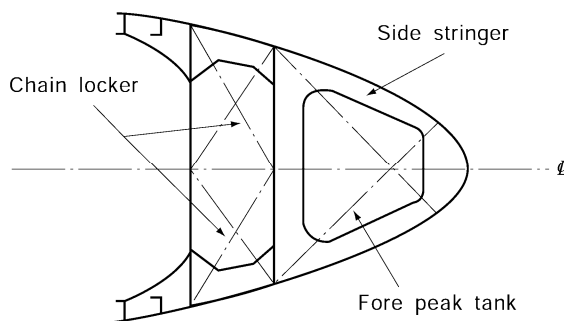

Fig 10.13.1 Construction and arrangement to resist panting in way of chain locker ↴

## CHAPTER 14 WATERTIGHT BULKHEADS

### Section 1 Arrangement

#### 101. Collision bulkheads **【See Rule】**

As specified in Pt 3, Ch 14, 201. of the Guidance.

#### 104. Hold bulkheads **【See Rule】**

As specified in Pt 3, Ch 14, 204. of the Guidance.

#### 107. Chain lockers **【See Rule】**

1. In application to 107. 1 of the Rules, the term "Bulkheads between separate cable lockers, or which form a common boundary of cable lockers" is referred to Fig 10.14.1.

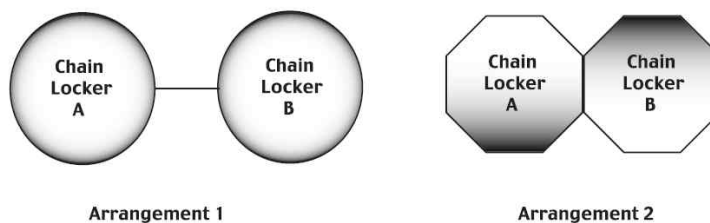

Fig 10.14.1 Arrangements of chain Locker

2. In application to 107. 4 of the Rules, examples of acceptable arrangements of the term "permanently attached closing appliances to minimize water ingress" are as follows.
  - (1) Steel plates with cutouts to accommodate chain links
  - (2) Canvas hoods with a lashing arrangement that maintains the cover in the secured position

### Section 2 Construction

#### 203. Stiffeners **【See Rule】**

As specified in Pt 3, Ch 14, 303. of the Guidance.

---

### Section 3 Watertight Doors (2020)

**302. Type of Watertight Doors [See Rule]**

As specified in Pt 3, Ch 14, 402. of the Guidance.

**303. Strength and watertightness [See Rule]**

As specified in Pt 3, Ch 14, 403. of the Guidance.

**304. Control [See Rule]**

As specified in Pt 3, Ch 14, 404. of the Guidance.

**305. Indication [See Rule]**

As specified in Pt 3, Ch 14, 405. of the Guidance.

**306. Alarms [See Rule]**

As specified in Pt 3, Ch 14, 406. of the Guidance.

**307. Source of Power [See Rule]**

As specified in Pt 3, Ch 14, 407. of the Guidance.

**309. Sliding Doors [See Rule]**

As specified in Pt 3, Ch 14, 409. of the Guidance.

**311. Test [See Rule]**

As specified in Pt 3, Ch 14, 412. of the Guidance. ↓

---

## CHAPTER 15 DEEP TANKS

### Section 1 General

#### 103. Divisions in tanks **【See Rule】**

As specified in Pt 3, Ch 15, 103. of the Guidance.

### Section 2 Bulkheads of Deep Tanks

#### 202. Bulkhead plates (2020) **【See Rule】**

As specified in Pt 3, Ch 15, 202. of the Guidance.

#### 203. Bulkhead stiffeners **【See Rule】**

As specified in Pt 3, Ch 15, 203. of the Guidance.

#### 204. Girders supporting bulkhead stiffeners **【See Rule】**

As specified in Pt 3, Ch 15, 204. of the Guidance. ⚡

---

## CHAPTER 16 SUPERSTRUCTURES AND DECKHOUSES

### Section 1 General

#### 101. Application (2019) [See Rule]

1. In application to **101. 1** of the Rules, the forecastle for fishing vessels may be omitted provided that they are satisfied with the relevant requirements of Standard for Fishing Vessel's Structure of Fishing Vessel Act.
2. In application to **101. 3** of the Rules, the construction and scantlings of the superstructures above the third tier are to be applied as if they are in third tier.

### Section 3 Access Openings in Superstructure End Bulkheads

#### 301. Closures for access openings [See Rule]

As specified in Pt 3, Ch 16, 301. of the Guidance. ↓

## CHAPTER 17 MACHINERY SPACES AND ENGINE CASINGS

### Section 1 General

#### 102. Compensation [See Rule]

Sectional area of face plates of web frames in machinery spaces is not to be less than the values obtained from following formula. However, scantlings of web frames may be determined by the other suitable calculation approved by the Society.

$$A = \frac{8KSL}{d_w} - \frac{d_w t_w}{600} \quad (\text{cm}^2)$$

Where :

$K$  = coefficient obtained in following formula

in case that  $P$  is equal to  $C$  and over :  $K = 0.4(P/C - 1) + 1$

in case that  $P$  is less than  $C$  :  $K = 0.2(P/C - 1) + 1$

$P$  = maximum continuous output of main engine (PS)

$C$  = coefficient obtained in following formula

in case that ships are 50 m in length and smaller :  $C = 10 L$

in case that ships are over 50 m in length :  $C = 35 L - 1250$

$l$  = vertical distance from the top of inner bottom platings to the top of beams of lowest deck at side of ships (m)

$S$  = spacing of web frames (m)

$L$  = length of ships (m)

$d_w$  = depth of web plates of web frames (mm)

$t_w$  = thickness of web plates of web frames (mm)

### Section 2 Main Engine Foundations

#### 201. Ships with single bottoms [See Rule]

Where spacing of girders beneath main engines is narrow, center girder may be omitted. However, intercostal plates are recommended to be fitted with along centre line.

#### 202. Ships with double bottoms [See Rule]

As specified in Pt 3, Ch 18, 202. of the Guidance. ↓

---

## CHAPTER 19 HATCHWAYS AND OTHER DECK OPENINGS

### Section 1 General

#### 101. Application **【See Rule】**

1. Hatchways and other deck openings are to comply with **Pt 4, Ch 2** of the Guidance.
2. For the ships classed for restricted service area, as specified in **Ch 1, 201.** of the Guidance. ⚓

---

## CHAPTER 21 BULWARKS, FREEING PORTS, SIDE SCUTTLES, VENTILATORS AND PERMANENT GANGWAYS

### Section 2 Freeing Ports 【See Rule】

#### 202. Area of freeing ports

As specified in Pt 4, Ch 4, 202. of the Guidance.

#### 203. Arrangement of freeing ports

As specified in Pt 4, Ch 4, 203. of the Guidance.

### Section 3 Side Scuttles 【See Rule】

#### 302. Application

As specified in Pt 4, Ch 4, 303. of the Guidance. ↓

## CHAPTER 22 EQUIPMENT NUMBER AND EQUIPMENT

### Section 1 General

#### 101. General and application (2020) [See Rule]

1. When Danforth anchors with special shapes and dimensions are used on ships less than 30 meters in length, shall comply with requirements in this chapter. Type approval is required if the anchor does not comply with the dimensions specified in **Table 10.22.2** or exceeds a mass of 120 kg. (2025)
2. Where the equipment number is to be calculated in accordance with the requirements of **57** of Regulation for Ships Equipment of **Korean Ship Safety Act**, danforth anchor, anchor ropes and mooring ropes in specified **Table 10.22.1** may be provided with according to the equipment number. If the rope is not of the type specified in **Table 10.22.1**, other ropes having a minimum breaking strength equal to or greater than that of the ropes specified may be used. In this case, international standards (ISO, etc.) or recognized industrial standards (KS, DIN, etc.) of the country in which the ship was built may be applied. (2026).

**Table 10.22.1 Danforth anchor and ropes (2026)**

Equipment Number		Danforth Anchor		Ropes for anchor(per each anchor)						Tow Line (Manilar Rope)		Mooring Line (Manilar Rope)		
Exceeding	Not exceeding	Number	Mass per abchor (kg)	Length (m)	Diameter (mm)					Length (m)	Diameter (mm)	Number	Length (m)	Diameter (mm)
					Manilar Rope	Nylon Rope	Vinyl Rope	Chain						
								Grade 1	Grade 2					
80	90	2	20	60	24	17	20	.	.	110	28	.	.	.
90	105	2	25	70	28	20	24	.	.	110	30	1	165	20
105	140	2	30	80	32	22	27	.	.	110	32	1	165	20
140	175	2	40	90	35	25	30	.	.	135	34	1	165	22
175	215	2	50	100	38	27	33	.	.	135	36	1	165	24
215	255	2	60	100	42	30	36	14	12.5	135	40	1	165	24
255	295	2	70	110	45	32	38	14	12.5	135	45	1	165	24
295	390	2	95	110	50	35	42	16	14	135	50	1	165	32
390	445	2	125	120	60	42	50	17.5	16	135	50	1	165	32

3. Dimensions of danforth anchor are to be in accordance with the **Table 10.22.2.** and other danforth anchors having dimensions not specified in above **Par 1** and **Par 2** are to be in accordance with the discretion of the Society.

**Table 10.22.2 Dimensions of danforth anchor**

Size(mm) Weight(kg)	A	B	C	D	E	F	G
20	825	463	361	685	95	18	23
25	890	500	390	740	104	20	25
30	945	565	414	784	109	21	26
40	1,049	590	460	872	122	24	29
50	1,154	647	506	960	134	26	32
60	1,190	668	521	988	137	27	33
75	1,280	719	561	1,063	149	29	35
100	1,400	790	616	1,170	163	31	43
120	1,500	840	657	1,240	174	34	45

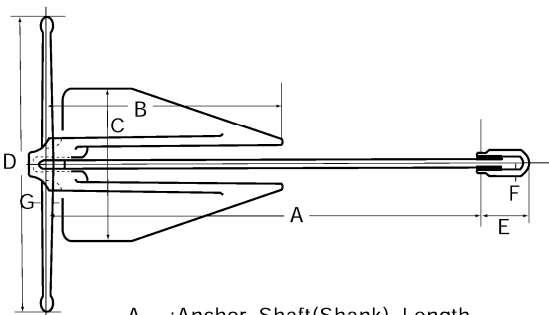
A :Anchor Shaft(Shank) Length  
 B :Bill(pea)↔Stock Center  
 C :Anchor Arm(p)↔Anchor Arm(s)  
 D :Stock length  
 E :Anchor Ring(Shackle) Length  
 F :Anchor Ring(Shackle) Dia.  
 G :Stock Dia.



## CHAPTER 23 OIL TANKERS

### Section 1 General

#### 101. Application **【See Rule】**

In application to **101. 3** of the Rules, the term "the satisfaction of the Society" means **Pt 7, Ch 1, 101. 3** of the Guidance.

#### 102. Arrangement of bulkheads **【See Rule】**

As specified in **Pt 7, Ch 1, 102.** of the Guidance.

#### 103. Cofferdams **【See Rule】**

As specified in **Pt 7, Ch 1, 103.** of the Guidance.

#### 104. Airtight bulkheads **【See Rule】**

As specified in **Pt 7, Ch 1, 104.** of the Guidance.

#### 108. Thickness of structural members in cargo oil spaces **【See Rule】**

With respect to the requirements of **108.** (4) and (6) of the Rules, these requirements are applied to cargo oil tank and deep tank with longer length or width than  $0.1L + 5.0$  (m).

### Section 2 Hatchways, Gangways and Freeing Arrangements

#### 201. Ships having unusually large freeboard **【See Rule】**

In application to **201.** of the Rules, the term "relaxation" means **Pt 3, Ch 1, 203. 2 (2) (E)** of the Guidance.

#### 202. Hatchways to cargo oil tanks **【See Rule】**

In application to **202. 2** of the Rules, the term "the discretion of the Society" means **Pt 7, Ch 1, 202.** of the Guidance.

#### 204. Permanent gangway and passage **【See Rule】**

In application to **204. 1** of the Rules, the term "the satisfaction of the Society" means **Pt 4, Ch 4, 501.** of the Guidance.

#### 205. Freeing arrangements **【See Rule】**

As specified in **Pt 7, Ch 1, 205.** of the Guidance.

### Section 6 Bulkheads in Cargo Oil Space

#### 603. Additional strengthening of bulkhead in large tanks **【See Rule】**

In application to **603.** of the Rules, the term "as required by the Society" means **Pt 7, Ch 1, 510.** of the Rules. ↓

## CHAPTER 24 DOUBLE HULL TANKERS

### Section 1 General

#### 101. Application **【See Rule】**

1. As specified in **Pt 7, Ch 10, 101.** of the Guidance.
2. In application to **101. 3** of the Rules, the term "deemed appropriate by the Society" means **Ch 7, Ch 10, 101. 2** and **3** of the Guidance. **【See Rule】**

#### 3. Minimum distance between asphalt cargo tank and the adjacent members

For asphalt carrier which all cargo tanks are independent tank, the requirements of minimum distance between asphalt cargo tank and the adjacent members are to be in accordance with the requirements in **Pt 7, Ch 1, 101. 4** of the Guidance.

#### 102. Arrangement and separation of spaces **【See Rule】**

As specified in **Pt 7, Ch 10, 102.** of the Guidance.

#### 103. Minimum thickness **【See Rule】**

With respect to the requirements of **103. 1** and **2** of the Rules, these requirements are applied to cargo oil tank and deep tank with longer length or width than  $0.1L + 5.0$  (m).

### Section 2 Bulkhead Platings

#### 202. Swash bulkheads **【See Rule】**

As specified in **Pt 7, Ch 10, 202.** of the Guidance.

### Section 10 Special Requirements for Hatchways and Permanent Gangways

#### 1001. Ships having unusually large freeboard **【See Rule】**

In application to **1001.** of the Rules, the term "relaxation" means **Pt 3, Ch 1, 203. 2 (2) (E)** of the Guidance. ↓

Rules for the Classification of Steel Ships  
Guidance Relating to the Rules for the  
Classification of Steel Ships

---

**PART 10 HULL STRUCTURE AND EQUIPMENT OF  
SMALL STEEL SHIPS**

Published by

**KR**

36, Myeongji ocean city 9-ro, Gangseo-gu,  
BUSAN, KOREA

TEL : +82 70 8799 7114

FAX : +82 70 8799 8999

Website : <http://www.krs.co.kr>

---

Copyright© 2026, **KR**

Reproduction of this Rules and Guidance in whole or in  
parts is prohibited without permission of the publisher.